

Turkish validity and reliability study of the Feeling Safe During Surgery Scale

Hamdiye Banu Katran,¹ Nurgül Arpag,² Fatma Eti Aslan,³ Fethi Gül⁴

¹Department of Nursing, Department of Surgical Nursing, Marmara University, Faculty of Health Sciences, İstanbul-Türkiye

²Department of Nursing, İstanbul Atlas University, Faculty of Health Sciences, İstanbul-Türkiye

³Department of Nursing, Bahçeşehir University, Faculty of Health Sciences, İstanbul-Türkiye

⁴Department of Anaesthesiology and Reanimation, Marmara University, School of Medicine, Surgical Medical Sciences, İstanbul-Türkiye

ABSTRACT

BACKGROUND: This study was conducted methodologically to evaluate the Turkish validity and reliability of the Feeling Safe During Surgery Scale and to assess its suitability for the Turkish population.

METHODS: This methodological validity and reliability study collected data from 148 patients who underwent elective surgery with regional anesthesia in the general surgery clinics of a university hospital in İstanbul between December 1, 2021 and June 30, 2022. Data were obtained through face-to-face interviews with patients using the Patient Information Form, developed by the researchers based on the literature, and the Turkish version of the Feeling Safe During Surgery Scale, originally created in Swedish. The Statistical Package for the Social Sciences (SPSS) Amos 26 was used for data analysis.

RESULTS: The content validity index of the scale was determined to be 0.96. Confirmatory factor analysis indicated that the Turkish version of the Feeling Safe During Surgery Scale was acceptably compatible with the original scale. The adapted Turkish version was found to have a comprehensible language structure and appropriate content. Cronbach's alpha coefficient for the total score was $\alpha=0.839$, indicating a high level of reliability. Consequently, the Turkish version of the Feeling Safe During Surgery Scale was determined to be valid, reliable, and stable over time.

CONCLUSION: The Turkish version of the Feeling Safe During Surgery Scale is a valid and reliable instrument that can be used in the Turkish population for assessing the sense of safety in patients undergoing elective surgery with regional anesthesia in surgical units.

Keywords: Feeling safe; reliability; surgery; validity.

INTRODUCTION

The need for security is one of the fundamental needs identified by Maslow (1970) in his hierarchy of needs. All living beings seek to feel safe. In this context, individuals tend to fear and avoid unfamiliar environments, situations, and the unknown. The distress and fear experienced when individuals perceive a threat to their physical or mental well-being are among the causes of anxiety.^[1,2] Being in a healthcare institution for treatment, receiving inpatient care, undergoing surgery, the

personal significance of the surgery, lack of information about the surgical process, disruption of daily life activities, being in an unfamiliar environment, and undergoing various medical treatments can all contribute to anxiety in patients receiving healthcare.^[3] In addition, the complex structure of the operating room environment and the experience of receiving anesthesia can cause anxiety and fear in patients, negatively impacting their sense of safety.^[1,3,4] As in every stage of the surgical process, creating a positive environment where patients are supported both physically and mentally in operating

Cite this article as: Katran HB, Arpag N, Eti Aslan F, Gül F. Turkish validity and reliability study of the Feeling Safe During Surgery Scale. *Ulus Travma Acil Cerrahi Derg* 2025;31:226-232.

Address for correspondence: Hamdiye Banu Katran

Department of Nursing, Department of Surgical Nursing, Marmara University, Faculty of Health Sciences, İstanbul, Türkiye

E-mail: banu-katran@hotmail.com

Ulus Travma Acil Cerrahi Derg 2025;31(3):226-232 DOI: 10.14744/tjtes.2024.73814

Submitted: 04.10.2024 Revised: 09.10.2024 Accepted: 06.12.2024 Published: 03.03.2025

OPEN ACCESS This is an open access article under the CC BY-NC license (<http://creativecommons.org/licenses/by-nc/4.0/>).



rooms, where complex procedures are performed, is essential for patient safety.^[5] The surgical process begins with the patient's decision to undergo surgery and continues through discharge and home care.^[6] Trust in nurses during this process is critical for patient satisfaction.^[5-7] Additionally, understanding patients' experiences in both the surgical clinic and the operating room, as well as how they feel, is important.^[8]

According to data from the General Directorate of Health Services in 2021, a total of 4,704,094 people in Türkiye underwent surgery in public, private, and university hospitals for various reasons.^[9] Given the high number of surgeries performed, it cannot be assumed that every patient always feels safe during hospitalization or surgery.^[10] A patient's perception of safety in the operating room environment positively influences both postoperative recovery and quality of care.^[11] Although patients undergoing surgery with regional anesthesia are typically under the influence of sedatives or mild sedation, the inability to feel their body as usual or move as they wish can also contribute to anxiety.^[12-14]

In this study, we used the Feeling Safe During Surgery Scale (FSDSS), developed by Larsson et al. in 2021,^[15] to evaluate the perception of safety in the surgical process among patients undergoing surgery with regional anaesthesia. The aim of the study was to assess its suitability for the Turkish population and to conduct a validity and reliability study in Turkish.

MATERIALS AND METHODS

Study Design, Setting, and Sample

This study is methodological and descriptive. The study population consisted of all patients who underwent elective surgery with regional anaesthesia in the general surgery clinics of the relevant hospital between December 1, 2021 and June 30, 2022. Although different approaches exist for determining an appropriate sample size when adapting a scale to another culture, it is generally recommended that the sample size be 5 to 10 times the number of scale items for factor analysis.^[16] Based on this guideline, the required sample size for the validity and reliability analysis of the 13-item Feeling Safe During Surgery Scale was determined to be 130 (13 x 10). However, the final study sample consisted of 148 patients who met the inclusion criteria and voluntarily participated.

Ethics committee approval was obtained from Health Science University Bakırköy Dr. Sadi Konuk Training and Research Hospital Clinical Research Ethics Committee (Approval Number: 2022-04-01, Date: 21.02.2022). Institutional permission was granted by the hospital where the study was conducted, and written informed consent was obtained from all participants. Additionally, permission to use the FSDSS was obtained from the original author.

Inclusion Criteria

- Undergoing elective surgery (excluding cesarean section),

- Receiving regional anesthesia,
- Aged between 18 and 65 years,
- No communication impairments.

Data Collection

In this study, data were collected using the Patient Information Form, which consisted of 10 questions, and the Feeling Safe During Surgery Scale.

Patient Information Form: This form, developed by the researchers, aimed to capture the socio-demographic characteristics of the participants. It included 10 questions covering age, gender, education level, employment status, type of surgery, anesthesia method, history of previous surgery, anesthesia method used in previous surgeries, and the number of prior surgeries if applicable.^[8,10,11,15]

Feeling Safe During Surgery Scale (FSDSS): The Feeling Safe During Surgery Scale was developed by Larsson et al.^[15] in 2021 in Sweden to assess the perception of safety patients undergoing surgery with regional anesthesia during the peri-operative process. The scale consists of 13 items, each scored on a 10-point scale (1 = completely negative, 10 = completely positive) yielding a total score ranging from 13 to 130. Higher scores indicate a greater sense of safety during the surgical process. The Cronbach's alpha internal consistency coefficient of the original scale was 0.88.

The original Swedish version of the scale was translated into English by its original author. It was then translated from English to Turkish by three academics fluent in both Turkish and English. These translations were subsequently evaluated by another Turkish academic fluent in English. This Turkish version was then translated back into English by another expert who was not familiar with the original scale but was fluent in both Turkish and English. The translated English version was then evaluated, and a comparison was made between the original and translated scales. To determine content validity, the Turkish version of the scale was submitted for review to eight (8) academicians with at least a PhD degree and expertise in their respective fields. The experts provided feedback using a four-point rating scale:

- 4: Very Appropriate
- 3: Appropriate
- 2: Not Appropriate
- 1: Not Appropriate at All.

The content validity index (CVI) was calculated using the Davis technique. The lowest CVI score was 0.875, the highest was 1.0, and the total value was determined to be 0.96. Additionally, no items had a CVI below 0.8. As a result, it was observed that the Turkish-adapted scale had a comprehensible language structure and appropriate content.^[16] Once content validity was confirmed, a preliminary study was conducted with 30 patients who met the inclusion criteria to

assess whether any items in the form were unclear. Patients who participated in the preliminary study were not included in the final study sample.

All patients were informed about the research protocol in the postoperative period. After obtaining their written consent, they were asked to complete the Patient Information Form and FSDSS through a face-to-face interview conducted by the researcher.

Statistical Analysis

For statistical analyses, SPSS (Statistical Package for the Social Sciences) version 26 (IBM Corp., Armonk, NY, USA) and IBM SPSS Amos 26 were used to evaluate the study findings. The normal distribution of scores obtained from each continuous variable was assessed using descriptive, graphical, and statisti-

cal methods. The Kolmogorov-Smirnov test was applied to statistically evaluate the normality of continuous variables. To assess reliability, Cronbach's alpha reliability coefficients were calculated, and the Intraclass Correlation Coefficient (ICC) was used to determine test-retest agreement. In addition to descriptive statistical methods (such as number, percentage, mean, standard deviation, etc.), Pearson correlation test was conducted to analyze the relationship between two continuous variables. For validity analyses, exploratory and confirmatory factor analyses were performed, along with goodness-of-fit statistics. All results were evaluated at a 95% confidence interval, with significance set at $p < 0.05$.

RESULTS

Descriptive data of the patients who participated in the study are presented in Table 1.

Table 1. Characteristics of participants (n=148)

Variables	n (%)
Age	
18-25	17 (11.5)
26-35	20 (13.5)
36-45	30 (20.3)
46-55	27 (18.2)
56-65	22 (14.9)
≥66	32 (21.6)
Gender	
Female	48 (32.4)
Male	100 (67.6)
Education Level	
Primary School	20 (13.5)
Middle School	21 (14.2)
High School	52 (35.1)
University	55 (37.2)
Employment Status	
Unemployed	66 (44.6)
Employed	82 (55.4)
Surgical Procedure	
Lumbar Discectomy	34 (23)
General Surgeries (e.g., inguinal hernia, anal fistula, appendectomy, stoma closure, hysterectomy, myomectomy)	76 (51.4)
Minimal Invasive Surgeries (e.g., arthroscopy, cystoscopy, transurethral resection, prostate stent placement)	31 (20.9)
Ophthalmology Surgeries (e.g., cataract)	7 (4.7)
Anesthesia Method	
Spinal Anesthesia	129 (87.2)
Epidural Anesthesia	5 (3.4)
Nerve Block	3 (2)
Other (excluding general anesthesia)	11 (7.4)
Previous Surgical Procedure	
No	92 (62.2)
Yes	56 (37.8)

Table 2. Item statistics

Factor	Item No	Item	CITC*	Mean (SD)	Cronbach Alpha (α)	
Factor 1	1	During the operation, did you feel that the surgical team was concerned about your well-being?	0.545	9.11 (1.20)	0.883	
	2	What was your experience of the treatment by the surgical team?	0.550	8.97 (1.25)		
	3	How was the approach/behavior of the surgical team towards you?	0.662	9.02 (1.13)		
	4	Did you feel that the surgical team took your needs into account?	0.645	8.03 (1.69)		
	5	What was your experience/opinion about the information provided to you during the operation?	0.709	8.34 (1.52)		
	6	How was the communication between you and the surgical team?	0.707	9.13 (1.07)		
	9	Did you trust the surgical team?	0.652	9.43 (0.91)		
	10	What was your experience with monitoring/follow-up of your general health during the surgery?	0.677	8.95 (1.00)		
	Factor 1-Total					8.87 (0.92)
	Factor 2	7	Did you know what to expect during your stay in the operating room?	0.432		5.66 (2.96)
8		Did you have emotional control during the surgery? (Were you able to manage complex emotions such as sudden tearfulness/excessive laughter/or anxiety)?	0.400	6.26 (2.87)		
11		Did you feel safe before the surgery?	0.357	9.29 (1.08)		
12		Did you feel safe during your surgery?	0.603	8.93 (1.27)		
13		Did you feel safe after your surgery?	0.399	9.81 (0.70)		
Factor 2-Total				7.99 (1.17)		
Total				8.53 (0.92)	0.839	

*CITC: Corrected Item-Total Correlation; SD: Standard Deviation.

Results on the Scale's Validity and Reliability

Reliability Analyses

When the total and subscale Cronbach's alpha values of the Feeling Safe During Surgery Scale were examined, the reliability coefficient for the total score of the FSDSSS was $\alpha=0.839$, $\alpha=0.883$ for the first factor subscale, and $\alpha=0.510$ for the second factor subscale. With these findings, it was determined that the total reliability level of the FSDSS scale was high. When the item-total score correlation of the 13 items in the scale was analyzed, the correlation coefficients ranged from $r=0.36$ to $r=0.71$, showing a positive and sufficient relationship among the items (Tables 2 and 3).

Validity Analyses

Confirmatory Factor Analysis (CFA)

To assess construct validity, CFA was conducted for the Turkish adaptation of the scale. Figure 1 illustrates the CFA standardized path coefficients, factor loadings, and error values. The standardized factor loadings were greater than 0.30, while the standardized error values were less than 0.90. These findings indicate that the model items effectively rep-

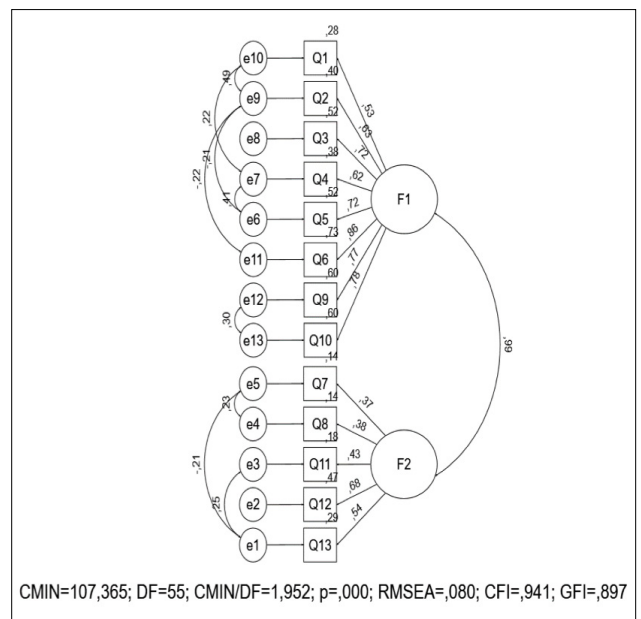

Figure 1. Measurement model and factor loadings of the Feeling Safe During Surgery Scale (FSDSS) confirmatory factor analysis outputs.

Table 3. Cnter-item correlations

	Item 1	Item 2	Item 3	Item 4	Item 5	Item 6	Item 7	Item 8	Item 9	Item 10	Item 11	Item 12
Item 2	0.659											
Item 3	0.457	0.397										
Item 4	0.481	0.408	0.547									
Item 5	0.392	0.359	0.593	0.667								
Item 6	0.451	0.456	0.657	0.510	0.593							
Item 7	0.265	0.240	0.243	0.388	0.371	0.225						
Item 8	0.220	0.177	0.394	0.269	0.402	0.326	0.353					
Item 9	0.363	0.509	0.561	0.400	0.504	0.675	0.264	0.229				
Item 10	0.380	0.506	0.532	0.413	0.532	0.654	0.312	0.247	0.717			
Item 11	0.217	0.274	0.207	0.256	0.204	0.366	0.184	0.037	0.439	0.428		
Item 12	0.278	0.346	0.466	0.515	0.556	0.581	0.305	0.225	0.495	0.533	0.311	
Item 13	0.340	0.466	0.245	0.165	0.298	0.475	0.021	0.092	0.455	0.500	0.412	0.381

Table 4. Fit index values obtained from confirmatory factor analysis (CFA)

Compliance Criteria	Good Fit Criteria	Acceptable Fit Criteria	Fit Index Results
χ^2/df	$0 \leq \chi^2/df \leq 2$	$2 \leq \chi^2/df \leq 3$	1.95
RMSEA	$0 < RMSEA < 0.05$	$0.05 < RMSEA < 0.08$	0.08
SRMR	$0 < SRMR < 0.05$	$0.05 < SRMR < 0.10$	0.06
NFI	$0.95 < NFI < 1.00$	$0.90 < NFI < 0.95$	0.89
NNFI (TLI)	$0.97 < NNFI < 1.00$	$0.95 < NNFI < 0.97$	0.92
CFI	$0.97 < CFI < 1.00$	$0.95 < CFI < 0.97$	0.94
GFI	$0.95 < GFI < 1.00$	$0.90 < GFI < 0.95$	0.90
RFI	$0.90 < RFI < 1.00$	$0.85 < RFI < 0.90$	0.84

RMSEA: Root Mean Square Error of Approximation; SRMR: Standardized Root Mean Square Residual; NFI: Normed Fit Index; NNFI: Non-Normed Fit Index; CFI: Comparative Fit Index; GFI: Goodness of Fit Index; RFI: Relative Fit Index.

represent the intended construct. Table 4 presents the fit index values obtained from the CFA of the FSDSS, including χ^2/df , Root Mean Square Error of Approximation (RMSEA), Standardized Root Mean Square Residual (SRMR), Normed Fit Index (NFI), Non-Normed Fit Index (NNFI/TLI), Comparative Fit Index (CFI), Goodness-of-Fit Index (GFI), and Relative Fit Index (RFI). The RMSEA and SRMR values were calculated as 0.080 and 0.060, respectively. The chi-square value was statistically significant ($\chi^2=107.365$; $n=148$, $df=55$, $p<0.001$). The χ^2/df ratio was 1.95, which is less than 2, indicating that the model falls within the limits of a good fit. Additionally, the other fit index values in the table meet the acceptable fit criteria.

The mean total score of the Feeling Safe During Surgery Scale was 8.53 ± 0.92 , the mean score for the external aspects subscale of the FSDSS was 8.87 ± 0.92 , and the mean score for the

Table 5. Test-retest reliability of the Feeling Safe During Surgery Scale (FSDSS) (n=39)

Feeling Safe During Surgery Scale	Test	Retest
$\bar{X} \pm SD$	8.53 ± 0.92	9.04 ± 1.10
ICC	$r=0.733^*$	
Cronbach's Alpha	$\alpha=0.751$	

* $p<0.001$; ICC: Intraclass Correlation Coefficient; \bar{X} : Arithmetic Mean; SD: Standard Deviation.

internal aspects subscale was 7.99 ± 1.17 . When analyzing the mean scores of the FSDSS, it was determined that the level of perceived safety during the surgical process was high. A statistically significant and positive correlation was found be-

tween the extrinsic and intrinsic subscale scores of the FSDSS ($r=0.646$; $p<0.001$).

Time Invariance

The Intraclass Correlation Coefficient was analyzed to assess test-retest reliability in a sample group of 39 participants. When the relationship between pretest and posttest scores was examined, a statistically significant, strong positive correlation was found between the pretest and posttest item total scores ($ICC=0.733$; $p<0.001$). Based on this finding, it was determined that the scale was stable over time (Table 5).

DISCUSSION

In scale adaptation studies, examining linguistic equivalence is a crucial first step. To ensure linguistic equivalence, the Turkish version of the FSDSS was evaluated by eight experts, and the CVI was determined to be 0.96, which is considered highly satisfactory.^[17] Furthermore, no difficulties were reported by the patients in answering the scale. Accordingly, it was observed that the language structure of the Turkish version of the FSDSS was clear and comprehensible, its content was appropriate.

For validity analyses, CFA and goodness-of-fit statistics were used. In terms of goodness of fit, the RMSEA, SRMR, and GFI values obtained from the CFA model indicated an acceptable fit. Furthermore, the Turkish version of the scale was found to be consistent with the factor structure of the original scale. Additionally, the $\chi^2/df=1.95$ (<2) confirmed that the model was within the limits of a good fit.^[18,19] The other fit index values also met the acceptable fit criteria.

The study findings showed that the total and subscale Cronbach's alpha reliability coefficient for the FSDSS was $\alpha=0.839$, indicating good internal consistency.^[20] The reliability coefficients for the two subscales were calculated as $\alpha=0.883$ for Factor 1 and $\alpha=0.510$ for Factor 2. A low alpha value may result from heterogeneous item structures or cultural differences.^[20,21] When scales are tested using data from different countries and regions, variations may occur in structural validity analyses. In the original version of the scale,^[15] two factor loadings were relatively low (<0.4), similar to this study (items 11 and 13). This may indicate a lower degree of construct validity;^[21,22] However, these items were retained in the scale due to their strong content validity.

When the item-total score correlation of the 13 items in the scale was examined, the correlation coefficients ranged from $r=0.36$ to $r=0.71$, indicating a positive and adequate relationship among the items. In the original version of the scale, the item correlations were also positive, ranging from $r=0.33$ to $r=0.73$.^[15] Based on these findings, the results of this study are consistent with those of the original scale.

The stability of the scale over time was assessed using a test-retest analysis. In a Pearson correlation test, a $p<0.05$ is expected to confirm the reliability of the scale.^[23] In this

context, it can be stated that the reliability of the scale is at a sufficient level, and the items in the scale consistently measure the intended construct. In the test-retest procedure, the scale was administered to the same group twice with a four-week interval, and the correlation between the two administrations was evaluated.^[24] A statistically significant high positive correlation was found between the pretest and posttest item total scores in a sample of 39 patients over one month ($ICC=0.733$; $p<0.001$). Based on this finding, it was concluded that the scale is time-invariant and demonstrates consistency.

Limitations of the Study

There are several limitations that may affect the results and generalizability of this study. First, while the sample size is adequate for the methodological framework, it may not fully represent the broader population of patients undergoing elective surgery with regional anesthesia. Additionally, the study was conducted in a single university hospital in Istanbul, which could introduce location-specific biases and limit the applicability of the results to other healthcare settings or geographical regions. Another limitation is the study's focus on patients aged 18 to 65, excluding older adults who may have different perceptions of safety during surgery. This demographic restriction may result in a limited understanding of safety perceptions among older patients, who often have more complex health needs. These limitations suggest that, while the findings are significant, further research is needed to examine these factors in a more diverse population and across multiple healthcare settings to strengthen the validity and reliability of the results.

CONCLUSION

In conclusion, the findings of this study demonstrate that the Turkish version of the FSDSS is a valid and reliable measurement tool for assessing the sense of safety in patients undergoing surgery with regional anaesthesia. Additionally, the results confirm that the scale is time-invariant and consistent.

Ethics Committee Approval: Ethics committee approval was obtained from Health Science University Bakırköy Dr. Sadi Konuk Training and Research Hospital Clinical Research Ethics Committee (Date: 21.02.2022, Decision No: 2022-04-01).

Peer-review: Externally peer-reviewed.

Authorship Contributions: Concept: H.B.K., N.A.; Design: H.B.K., N.A.; Supervision: H.B.K., N.A., F.E.A., F.G.; Resource: H.B.K., N.A.; Materials: H.B.K., N.A.; Data Collection and/or Processing: H.B.K., N.A.; Analysis and/or Interpretation: H.B.K., N.A.; Literature Review: H.B.K., N.A.; Writing: H.B.K., N.A., F.E.A., F.G.; Critical Review: H.B.K., N.A., F.E.A., F.G.

Conflict of Interest: None declared.

Financial Disclosure: The author declared that this study has received no financial support.

REFERENCES

1. Karabulut N, Gürçayır D, Abi Ö, Kızıloğlu Ağgöl B, Söylemez N. Does surgery cause anxiety, stress and fear in geriatric patients? *Psychogeriatrics* 2023;23:808–14. [CrossRef]
2. Kelly AC, Zuroff DC, Leybman MJ, Gilbert P. Social safeness, received social support, and maladjustment: Testing a tripartite model of affect regulation. *Cogn Ther Res* 2012;36:815–26. [CrossRef]
3. Rosén S, Svensson M, Nilsson U. Calm or not calm: The question of anxiety in the perianesthesia patient. *J Perianesth Nurs* 2008;23:237–46.
4. Herrera-Espiñeira C, Rodríguez del Aguila Mdel M, Rodríguez del Castillo M, Valdivia AF, Sánchez IR. Relationship between anxiety level of patients and their satisfaction with different aspects of healthcare. *Health Policy* 2009;89:37–45. [CrossRef]
5. Çakır SK, Özbayır T. Assessment of patient anxiety levels before and after stoma surgery. *Turk J Colorectal Dis* 2018;28:159–63. [CrossRef]
6. McMullan RD, Urwin R, Gates P, Sunderland N, Westbrook JI. Are operating room distractions, interruptions and disruptions associated with performance and patient safety? A systematic review and meta-analysis. *Int J Qual Health Care* 2021;33:mzab068. [CrossRef]
7. Alshyyab MA, Albsoul R, Fitzgerald G. Factors influencing patient safety culture in operating room in a teaching hospital in Jordan: A qualitative descriptive study. *TQM J* 2023;35:1722–42. [CrossRef]
8. Kenward L, Whiffen C, Spalek B. Feeling unsafe in the healthcare setting: Patients' perspectives. *Br J Nurs* 2017;26:143–9. [CrossRef]
9. T.C. Sağlık Bakanlığı. Sağlık istatistikleri yılı 2021. Available from: <https://dosyasb.saglik.gov.tr/Eklenti/45316,siy2021-turkcepdf.pdf?0>. Accessed Feb 17, 2025. [CrossRef]
10. Mollon D. Feeling safe during an inpatient hospitalization: A concept analysis. *J Adv Nurs* 2014;70:1727–37. [CrossRef]
11. Dahlberg K, Jaensson M, Nilsson U, Eriksson M, Odencrans S. Holding it together-patients' perspectives on postoperative recovery when using an e-assessed follow-up: Qualitative study. *JMIR Mhealth Uhealth* 2018;6:e10387. [CrossRef]
12. Bergman M, Stenudd M, Engström Å. The experience of being awake during orthopaedic surgery under regional anaesthesia. *Int J Orthop Trauma Nurs* 2012;16:88–96. [CrossRef]
13. Ericsson A, Hult C, Kumlien C. Patients' experiences during carotid endarterectomy performed under local anesthesia. *J Perianesth Nurs* 2018;33:946–55. [CrossRef]
14. Stamenkovic DM, Rancic NK, Latas MB, Neskovic V, Rondovic GM, Wu JD, et al. Preoperative anxiety and implications on postoperative recovery: What can we do to change our history. *Minerva Anestesiol* 2018;84:1307–17. [CrossRef]
15. Larsson F, Engström Å, Strömbäck U, Gustafsson S. Development and psychometric evaluation of the feeling safe during surgery scale. *Nurs Open* 2021;8:2452–60. [CrossRef]
16. Byrne BM. Structural equation modeling with AMOS: Basic concepts, applications, and programming, 3rd ed. New York, NY: Routledge; 2016.
17. DeVellis RF, Thorpe CT. Scale development: Theory and applications. 5th ed. Thousand Oaks, CA: Sage Publications; 2021. [CrossRef]
18. Moss TP, Lawson V, White P; Appearance Research Collaboration. Identification of the underlying factor structure of the derriford appearance scale 24. *PeerJ* 2015;3:e1070. [CrossRef]
19. Baharum H, Ismail A, Awang Z, McKenna L, Ibrahim R, Mohamed Z, et al. The study adapted instruments based on confirmatory factor analysis (CFA) to validate measurement models of latent constructs. *Int J Environ Res Public Health* 2023;20:2860. [CrossRef]
20. Tavakol M, Dennick R. Making sense of cronbach's alpha. *Int J Med Educ* 2011;2:53–5. [CrossRef]
21. Clark LA, Watson D. Constructing validity: New developments in creating objective measuring instruments. *Psychol Assess* 2019;31:1412–27. [CrossRef]
22. Flake JK, Davidson IJ, Wong O, Pek J. Construct validity and the validity of replication studies: A systematic review. *Am Psychol* 2022;77:576–88.
23. Brown TA. Confirmatory factor analysis for applied research. 2nd ed. New York, NY: Guilford Press; 2015. p. 33. [CrossRef]
24. Schumacker RE, Lomax RG. A beginner's guide to structural equation modeling. 4th ed. New York, NY: Routledge; 2016. [CrossRef]

ORIJİNAL ÇALIŞMA - ÖZ

Ameliyat sırasında kendini güvende hissetme ölçeğinin türkçe geçerlilik ve güvenilirlik çalışması

AMAÇ: Bu çalışma, "Ameliyat Sırasında Kendini Güvende Hissetme Ölçeği" nin Türkçe geçerlilik ve güvenilirliğini değerlendirmek ve Türk toplumuna uygunluğunu incelemek amacıyla metodolojik olarak gerçekleştirilmiştir.

GEREK VE YÖNTEM: Bu metodolojik geçerlik ve güvenilirlik çalışmasının verileri 01 Aralık 2021 ve 30 Haziran 2022 tarihleri arasında İstanbul'daki bir üniversite hastanesinin genel cerrahi kliniklerinde bölgesel anestezi ile elektif cerrahi geçiren 148 hastadan toplanmıştır. Verilerin toplanmasında, araştırmacılar tarafından literatür doğrultusunda hazırlanan "Hasta Bilgi Formu" ve orijinali İsveççe olan "Ameliyat Sırasında Kendini Güvende Hissetme Ölçeği" ölçeğinin Türkçe versiyonu aracılığıyla hastalarla yüz yüze görüşülerek elde edildi. Verilerin analizinde SPSS Amos 26 istatistiksel analiz programı kullanıldı.

BULGULAR: Ölçeğinin kapsam geçerlilik indeksi değeri 0.96 olarak belirlendi. Doğruluk faktör analizi, Ameliyat Sırasında Güvende Hissetme Ölçeği Türkçe formunun orijinal ölçekle kabul edilebilir düzeyde uyumlu olduğunu ortaya koydu. Türkçe'ye uyarlanan ölçeğin dil yapısının anlaşılır ve içeriğinin uygun olduğu belirlendi. Toplam puan için Cronbach alfa katsayısı $\alpha=0.839$ olup yüksek güvenilirlik düzeyinde olarak değerlendirildi. Sonuç olarak, Ameliyat Sırasında Kendini Güvende Hissetme Ölçeği'nin Türkçe versiyonu geçerli, güvenilir ve zaman içinde değişmez olduğu belirlendi.

SONUÇ: Ameliyat Sırasında Kendini Güvende Hissetme Ölçeği'nin Türkçe versiyonu, cerrahi birimlerde rejyonel anestezi ile elektif cerrahi geçiren hastaların cerrahi süreç boyunca kendilerini güvende hissetmelerini değerlendirmek için Türk toplumunda kullanılabilir geçerli ve güvenilir bir araçtır.

Anahtar sözcükler: Cerrahi; güvende hissetme; geçerlilik; güvenilirlik.

Ulus Trauma Acil Cerrahi Derg 2025;31(3):226-232 DOI: 10.14744/tjtes.2024.73814