

Optimization of CO₂ booster refrigeration cycle with flooded evaporators and parallel compressor by using the bees algorithm

CO₂ akışkanlı yaş evaporatörlü paralel kompresörlü booster soğutma çevriminin güç tüketiminin arı algoritması ile optimizasyonu

Metehan IŞIK^{1*}, Nahihan BİLİR SAG¹, Mete KALYONCU¹

¹Konya Technical University, Faculty of Engineering and Natural Sciences, Mechanical Engineering Department, Konya, Turkey.
misik@ktun.edu.tr, nbilir@ktun.edu.tr, mkalyoncu@ktun.edu.tr

Received/Geliş Tarihi: 24.06.2023
Accepted/Kabul Tarihi: 23.01.2024

Revision/Düzeltilme Tarihi: 12.01.2024

doi: 10.5505/pajes.2024.65171
Research Article/Araştırma Makalesi

Abstract

Energy supply is one of the most significant issues in modern society. So, energy saving becomes important in systems used frequently in daily life. Due to these energy saving concerns, there are numerous studies in literature to make supermarket refrigeration systems consume less energy. Among these studies, CO₂ booster refrigeration system with flooded evaporators and parallel compressor (BFP) seems as an energy-saving and nature-friendly choice. In this study, BFP was selected as the system of concern and the Bees Algorithm optimization was applied to get minimum power consumption (maximum COP). Gas cooler pressure (P_{gc}), intermediate pressure (P_{int}), and medium temperature (MT) level evaporator outlet quality (x_{14}) were chosen as optimization parameters. According to the optimization results, the Bees Algorithm converged well, and these three parameters were found worthy to optimize as they brought significant energy saving in total (up to 8.7% in comparison with constant intermediate pressure and MT evaporator outlet quality). As a result of this analysis, the optimal P_{gc} values were found to be between 7600 kPa and 12000 kPa at ambient temperatures ranging from 28 to 46°C. The optimal P_{int} values were found to be around 3500 kPa below ambient temperature of 14 °C and around 4500 kPa above this temperature. The optimal values for x_{14} ranged between 0.62 and 0.69. Additionally, annual energy consumption (AEC) and total equivalent emission (TEE) for 15 years were calculated for four different climate types. The highest AEC and TEE were obtained at tropical climate with 728.56 MWh and over 10000 tons, respectively. The lowest AEC and TEE were found at continental conditions as 380.01 MWh and almost 6000 tons of emission.

Keywords: The Bees Algorithm, optimization, refrigeration, carbondioxide, booster, supermarket.

Öz

Modern toplumdaki en önemli konulardan biri enerji tedarikiğidir. Bu nedenle günlük hayatta sıklıkla kullanılan sistemlerde enerji tasarrufu önem kazanmaktadır. Bu enerji tasarrufu hedeflerine yönelik süpermarket soğutma sistemlerinin daha az enerji tüketmesini amaçlayan çok sayıda çalışma literatürde bulunmaktadır. Bu çalışmalar arasında yaş evaporatörlü ve paralel kompresörlü CO₂ booster soğutma çevrimi (BFP) enerji tasarrufu ve doğa dostu bir seçim olarak ön plana çıkmaktadır. Bu çalışmada, BFP çevriminde minimum güç tüketimini (maksimum COP) elde etmek için Arı Algoritması optimizasyonu uygulanmıştır. Optimizasyon parametreleri olarak gaz soğutucu basıncı (P_{gc}), ara basınç (P_{int}) ve orta sıcaklık (MT) seviyesi evaporatörü çıkış kuruluk derecesi (x_{14}) seçilmiştir. Arı Algoritması optimizasyon sonuçlarına göre bu üç parametre, toplamda önemli ölçüde enerji tasarrufu sağlamaları sebebiyle (sabit ara basınç ve sabit MT evaporatör çıkış kuruluk derecesine kıyasla %8.7'ye kadar) optimize edilmeye değer bulunmuştur. Analiz sonucunda, optimum P_{gc} değerlerinin 28 °C ila 46 °C arasındaki çevre sıcaklıklarında 7600 kPa ile 12000 kPa arasında olduğu tespit edilmiştir. Optimum P_{int} değerlerinin 14 °C çevre sıcaklığının altında yaklaşık 3500 kPa ve bu sıcaklığın üstünde yaklaşık 4500 kPa olduğu bulunmuştur. x_{14} için optimum değerler 0.62 ile 0.69 arasında elde edilmiştir. Ayrıca dört farklı iklim tipi için yıllık enerji tüketimi (AEC) ve 15 yıllık toplam eşdeğer emisyon (TEE) hesaplanmıştır. En yüksek AEC ve TEE sırasıyla 728.56 MWh ve 10000 tonun üzerinde değerlerle tropikal iklimde elde edilmiştir. En düşük ise 380.01 MWh AEC ve yaklaşık 6000 ton TEE ile karasal iklimde bulunmuştur.

Anahtar Kelimeler: Arı Algoritması, optimizasyon, soğutma, karbondioksit, booster, süpermarket.

1 Introduction

One of the most important issues in the developing sectors that meet the requirements of humanity is to obtain enough energy supply. Besides the difficulties and limitations of producing energy to be used for the continuation of daily life, the human population is increasing, and cities are growing. As a result of these, being able to use energy more efficiently gains importance, and studies on it have an important place for researchers. A part of this energy saving effort is to make supermarket refrigeration systems consume less energy because most of the energy consumption of supermarkets comes from refrigeration systems used to keep food fresh[1]. Since supermarkets have a significant place in the basic nutritional needs of modern society, their numbers are increasing rapidly. Consequently, they cause higher energy

consumption day by day. Along with this, refrigeration systems indirectly cause deterioration of the climate with the gases released in the energy production processes. They also harm the environment directly with the refrigerants leaking from their installations.

Among the refrigerant alternatives with low global warming potential (GWP) and low ozone depletion potential (ODP) values in order to reduce the damage to nature caused by refrigerants, CO₂ keeps an important place in the literature with its non-flammable and non-toxic properties[2], high latent heat, specific heat, density, and thermal conductivity compared to HFC gases, and lower viscosity[1]. However, the critical point temperature of CO₂ is about 31 °C, and it performs heat rejection at the supercritical zone at higher ambient temperatures. In addition, its high operating pressures increase

*Corresponding author/Yazışılan Yazar

the equipment cost and energy consumption[2]. So, environmental benefits diminish when energy consumption is high. In the studies carried out to make CO₂ refrigeration systems consume less energy, special research has been made for the operation above the critical point. A non-linear relationship between temperature and pressure in this region has been determined and it has been shown that there is an optimum gas cooler pressure value that minimizes energy consumption[3]. There are many studies in the literature to determine this optimum pressure value[4, 5]. In addition, different cycles have been evaluated to make the systems more efficient. A system using two stage evaporator called CO₂ booster refrigeration system seems preferable, especially for supermarket applications[6–8]. Two evaporators in this system fulfill the requirement for fresh and frozen food preservation of the supermarkets in one cycle.

It has been seen in the literature; some improvements have been made on the basic version of the CO₂ booster refrigeration cycle. These improvements include the use of an auxiliary compressor at high-pressure level[9], flooded evaporators[10], mechanical subcooling[11, 12], evaporative cooling[13] etc. There are also city-based studies in the literature as a projection for the application of booster refrigeration systems to daily usage[11–19]. Among these studies, the CO₂ booster refrigeration cycle with flooded evaporators and parallel compressor (BFP) seems to be the most energy-saving solution in comparison with other booster system configurations[11, 12, 16, 19]. Further improvement of the equipment and operation parameters of this refrigeration cycle can bring more energy savings. It is hoped that a further optimization study can be beneficial for this purpose.

There are numerous studies on optimization of refrigeration cycles in the literature. In studies in this field, the objective function has been frequently selected as maximizing COP and exergy efficiency[20]. Deymi-Dashtebayaz et al. have examined the refrigerants with low GWP for the cascade refrigeration system to increase the COP and exergy efficiency. They have revealed the maximum COP and exergy efficiency values obtained at different evaporator and condenser temperatures[20]. Sun et al. also, have made an optimization study to improve COP and exergy efficiency by considering the use of a two-stage CO₂ refrigeration cycle with parallel compressor in their study[21].

Citarella et al. have evaluated seven low GWP refrigerants for various thermodynamic conditions and heat exchanger geometry and have revealed the optimal configuration with a thermo-economic analysis[22]. A geometry optimization for the CO₂ gas cooler/condenser has been brought to the literature by Ge et al[23]. Liu et al. have considered the booster system with parallel compressor and have optimized the gas cooler pressure and intermediate pressure value with genetic algorithm and presented its energetic, exergetic, and economic analysis[24].

Optimization means considering all possible input values of the chosen parameters to be performed at specified ranges and determining the best output according to the expectation of the problem. Calculating all scenarios for a lot of possibilities can be troublesome in determining the optimum inputs that give the best output. Various optimization methods have emerged in the studies carried out to reach the best result faster in the search spaces[25]. Some of these methods are population-based such as Genetic Algorithm[25] while some optimization methods have been implemented from the movements of

various animals such as Ant Colony Optimization and Particle Swarm Optimization[25]. One of these methods is the Bees Algorithm (BA). It originates from the bee dance which bees share the location and quality of the resource found in an area with each other to direct the colony to that place. BA can be used for various applications. Unal et al. have made an optimization study on solar chimneys[26]. They have selected maximum efficiency and minimum cost as objective function and tried to find optimum solar chimney dimensions. They have obtained 1293.05–1330.47 meters for the collector diameter, 94–99 meters for the chimney diameter and 783–792 meters for the chimney height. These dimensions provide over 56.75 MW electrical power and approximately 0.08 efficiency [26]. In the study of Fahmy et al., the effectiveness of BA in optimizing parameters for robot manipulator control has been presented [27]. BA has been applied to train neural networks for inverse kinematics and optimize proportional–integral–derivative controller gains, demonstrating superior results compared to traditional methods in both cases [27]. In another study of Fahmy for wind turbines, BA has been used for optimizing the operating speed parameters of wind power units, specifically the rated, cut-in, and cut-off speeds [28]. The objective has been selected as maximizing yearly power yield and turbine usage time based on wind frequency distribution at coastal sites in Egypt. Comparisons with Particle Swarm Optimization and manual optimization demonstrate BA's superior ability to enhance power yield without significant drawbacks, showcasing its effectiveness in optimizing multiple speed parameters for wind power units [28].

The study of Banooni et al. has demonstrated the successful application of BA to optimize the design of a cross-flow plate fin heat exchanger with offset strip fins[29]. The optimization focuses on minimizing the total annual cost and the total number of entropy generation units under given space constraints. Seven design parameters have been considered such as hot flow length, cold flow length, fin height, fin thickness, fin frequency, lance length of fin, and number of hot side fin layers. The results indicate that BA outperforms the Imperialist Competitive Algorithm and Genetic Algorithm in terms of speed and accuracy in detecting optimal configurations[29]. The study of Pham and Kalyoncu has demonstrated the usage of BA for optimizing the parameters of a fuzzy logic controller to minimize the vibration of the controller in motion [30]. The authors have presented the experimental results proving the efficiency and robustness of the design [30].

The optimization in this paper aims to minimize the system's power consumption. This objective function can also be defined as maximizing the coefficient of performance (COP). For this purpose, the gas cooler pressure (P_{gc}), liquid-vapor separator intermediate pressure (P_{int}), and medium temperature (MT) level flooded evaporator outlet quality (x_{14}) parameters of the CO₂ booster refrigeration cycle with flooded evaporator and parallel compressor (BFP) were chosen to be optimized. Optimization was planned to be done with BA for each ambient temperature in 0 °C–46 °C range.

With the optimum results obtained, it has been aimed to reveal the annual energy consumption (AEC) and total equivalent emission amount (TEE) calculations for tropical, arid, temperate, and continental climate types according to Koppen-Geiger classification.

Modeling and optimization have also been made by the Engineering Equation Solver (EES) [31] which is one of the

most used programs for thermodynamics analysis. In this study, mathematical modeling and the Bees Algorithm optimization have been carried out on MATLAB [32]. The innovative aspect of the study is the comparison of the results of the MATLAB program using the Bees Algorithm and the results of the EES program using the Genetic Algorithm.

2 Mathematical modeling

The schematic diagram and P-h diagram of the system to be optimized in this study are given in Figure 1 and Figure 2 respectively.

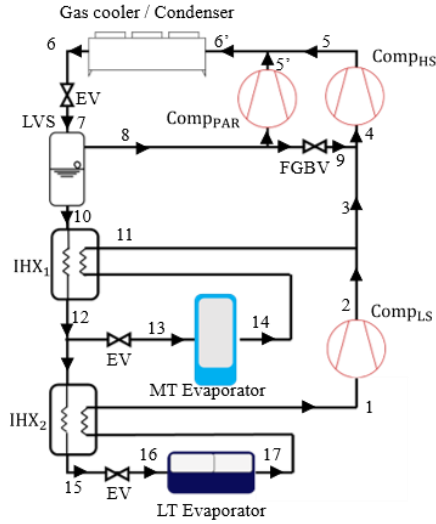

Figure 1. The schematic of the system.

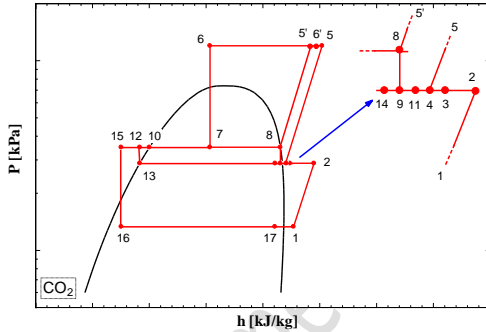

Figure 2. P-h diagram of the system.

This system consists of an MT evaporator for fresh food preservation and low temperature (LT) evaporator for frozen food. These are both flooded-type evaporators. Points 14 and 17 in the P-h diagram represent the evaporator outlets and are in the saturated liquid-vapor phase. One of the three compressors in the system is the low-pressure compressor (Comp_{LS}) and operates at low temperature, while the high-pressure compressor (Comp_{HS}) compresses the refrigerant to gas cooler/condenser pressure ($P_{gc/con}$). The parallel compressor (Comp_{PAR}) compresses the saturated vapor, which is at the intermediate pressure (P_{int}), to the gas cooler/condenser pressure.

In the transcritical operation, the heat rejection equipment is called gas cooler, but it functions as a condenser at subcritical conditions. The liquid-vapor separator (LVS) located after the gas cooler/condenser separates the refrigerant as saturated liquid and saturated vapor. While the saturated liquid (state 10) goes to the evaporators, the saturated vapor (state 8)

moves to the parallel compressor, flash gas bypass valve (FGBV) and high-pressure compressor.

There are four pressure levels and two of them are the saturation pressure at the evaporator temperatures, $-32\text{ }^\circ\text{C}$ and $-7\text{ }^\circ\text{C}$ for LT and MT, respectively[11]. The working pressure of the LVS is called the intermediate pressure (P_{int}). The highest pressure level in the cycle is the saturation pressure at the condenser temperature in subcritical operation. However, this pressure should have an optimum value that maximizes the COP in the transcritical operation. The pressure and temperature values of the gas cooler/condenser vary according to the ambient temperatures (T_{amb}) and are given in Table 1 [11, 15].

Table 1. Pressure and temperature values due to ambient temperature operating zones.

Operating Zones	Ambient Temperature Ranges ($^\circ\text{C}$)	Gas cooler outlet/condenser temperature ($^\circ\text{C}$)	Gas cooler/condenser pressure (kPa)
Subcritical 1 [11]	$T_{amb} < 2$	10	$P_{sat}@10\text{ }^\circ\text{C}$
Subcritical 2 [11]	$2 \leq T_{amb} < 14$	$T_{amb} + 8$	$P_{sat}@T_{con}$
Transition	$14 \leq T_{amb} < 28$	$0.642 T_{amb} + 13.007$	$98.283 T_{amb} + 4627.03$
Transcritical	$28 \leq T_{amb}$	$T_{amb} + 3$	optimized

Cooling capacity of the LT evaporator is taken 35 kW constant at all ambient temperatures[12]. However, MT evaporator's load is 100 kW below $10\text{ }^\circ\text{C}$ ambient temperature and 200 kW over $35\text{ }^\circ\text{C}$ [12]. It increases linearly between $10\text{ }^\circ\text{C}$ and $35\text{ }^\circ\text{C}$ from 100 kW to 200 kW[12]. MT evaporator cabinets are generally in contact with ambient air in supermarkets. So, changes in cooling loads with respect to ambient temperature are considered.

Conservation of mass and energy laws are applied at all calculations. Eqn. (1-3) are used for the calculation of mass flow rates of LVS. \dot{m}_7 represents the mass flow rate entering LVS. \dot{m}_8 is the vapor mass flow rate while \dot{m}_{10} shows the liquid phase. Higher quality at state point 7 (x_7) increases the vapor mass flow rate.

$$\dot{m}_8 = \dot{m}_7 x_7 \quad (1)$$

$$\dot{m}_{10} = \dot{m}_7 (1 - x_7) \quad (2)$$

$$\dot{m}_7 = \dot{m}_8 + \dot{m}_{10} \quad (3)$$

Heat exchanger energy balances are calculated by Eqn. (4) and Eqn. (5). In internal heat exchanger 1 (IHX₁), mass flow rate terms are omitted due to the equality of both sides'.

$$\dot{m}_{10}(h_{10} - h_{12}) = \dot{m}_{13}(h_{11} - h_{14}) \quad (4)$$

$$h_{12} - h_{15} = h_1 - h_{17} \quad (5)$$

Energy balances at mixing points are presented at Eqn. (6-8) as:

$$\dot{m}_3 h_3 = \dot{m}_2 h_2 + \dot{m}_{11} h_{11} \quad (6)$$

$$\dot{m}_4 h_4 = \dot{m}_3 h_3 + \dot{m}_9 h_9 \quad (7)$$

$$\dot{m}_{6'}h_{6'} = \dot{m}_5h_5 + \dot{m}_{5'}h_{5'} \quad (8)$$

MT and LT evaporator loads (\dot{Q}_{MT} and \dot{Q}_{LT}) are calculated by Eqn. 9 and Eqn. 10.

$$\dot{Q}_{LT} = \dot{m}_{16} * (h_{17} - h_{16}) \quad (9)$$

$$\dot{Q}_{MT} = \dot{m}_{13} * (h_{14} - h_{13}) \quad (10)$$

The heat rejected from CO₂ gas cooler/condenser ($\dot{Q}_{gc/cond}$) is calculated with Eqn. (11).

$$\dot{Q}_{gc/cond} = \dot{m}_{6'} * (h_{6'} - h_6) \quad (11)$$

The power consumptions of the compressors (\dot{W}) are given by Eqn. (12-14). Compressor total efficiencies (η) are taken from the study of Cui et al[11].

$$\dot{W}_{CompLS} = \frac{\dot{m}_1 * (h_{2,s} - h_1)}{\eta_{CompLS}} \quad (12)$$

$$\dot{W}_{CompHS} = \frac{\dot{m}_5 * (h_{5,s} - h_4)}{\eta_{CompHS}} \quad (13)$$

$$\dot{W}_{CompPAR} = \frac{\dot{m}_{5'} * (h_{5',s} - h_8)}{\eta_{CompPAR}} \quad (14)$$

The COP value is found by the ratio of cooling capacities to total power consumption.

$$COP = \frac{\dot{Q}_{MT} + \dot{Q}_{LT}}{\dot{W}_{CompLS} + \dot{W}_{CompHS} + \dot{W}_{CompPAR} + \dot{W}_{add}} \quad (15)$$

For mathematical model, these assumptions are done:

- Heat losses and pressure drops in the heat exchangers and pipes are neglected.
- It is assumed that all expansion valves perform isenthalpic processes.
- The CO₂ flooded evaporator outlet quality is accepted as 0.95 for LT evaporator[11]. This parameter is taken constant because it does not affect COP since the temperature of point 17 is constant saturation temperature.
- Internal heat exchanger (IHX) effectiveness is taken 0.65[11]. The effect of this parameter is almost negligible as it changes COP approximately 0.5% on average between the values from 0.10 to 1.
- Comp_{PAR} is activated at 14 °C ambient temperature[15]. Below that temperature, CO₂ enters the LVS with low quality. It results as low amount of vapor transfer to the parallel compressor. The benefit of using an auxiliary compressor is reduced significantly due to low mass flow rates.
- Additional power (\dot{W}_{add})(fans etc.) are assumed 3% of the heat rejected from gas cooler/condenser[11].

In order to examine the obtained results in different climatic conditions for the calculation of the AEC and the TEE, annual bin-hour data were modeled for four different climate types according to Koppen-Geiger classification[33]. Climate data of Rio de Janeiro[34], Mombasa[34], Chennai[10], and Port Louis[13] cities were used for modeling tropical climate type(A). The arid climate type modeling (B) includes Konya[35], Şanlıurfa[35], Phoenix[36], and Ahmedabad[10]. Temperate climate (C) was modeled according to Bursa[35],

Barcelona[12], Guangzhou[11] and London[37]. Finally, Erzurum[35], Oslo[37], Stockholm[12] and Beijing[11] were considered for continental climate (D) modeling. The generated bin hour model is given in Figure 3. Polar climatic regions were not considered due to their low population and low need for refrigeration systems in such cold conditions.

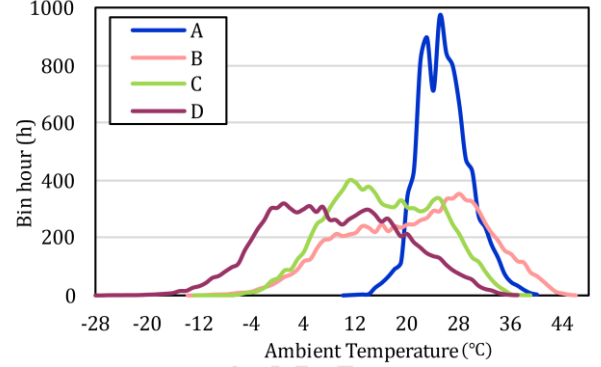

Figure 3. Bin-hour modeling for different climates

The AEC and TEE calculation for these climate types is given in the Eqn. (16) and Eqn. (17) respectively. In Eqn. (16), t represents the bin data at an ambient temperature while \dot{W} is the total power consumption at that ambient temperature. There are 75 ambient temperature points from -28 °C to 46 °C.

$$AEC = \sum_{i=1}^{i=75} t(i)\dot{W}(i) \quad (16)$$

TEE includes direct and indirect contributions to global warming. Direct part is proportional to the GWP and consist of the sum of M_{charge} which is the total refrigerant mass and leakages on system ($M_{leakage}$). Recycling factor (α) is taken 0.95 and operation period (n) is assumed to be 15 years [11]. In Eqn. (17) AEC multiplied by energy recovery factor ($RC=0.997$) and operation period is the indirect contribution term[11].

$$TEE = (M_{leakage}n + M_{charge}(1 - \alpha))GWP + RC * AEC * n \quad (17)$$

3 Optimization model

The optimization application made to consume less energy for the refrigeration system under consideration is explained in this section. The aim was to achieve the lowest energy consumption. So, the objective function was defined as maximizing the COP value for each ambient temperature. Optimization parameters were selected as gas cooler pressure (P_{gc}), intermediate pressure (P_{int}) and MT evaporator outlet quality (x_{14}). The Bees Algorithm (BA) was used for optimization. All calculations were made by MATLAB and refrigerant properties were obtained from COOLPROP [38].

The Bees Algorithm makes it possible for research scientists and engineers to solve complex problems involving vast amounts of data, categorizing the results according to specific criteria and then giving priority to the results most likely to yield workable solutions. The Bees Algorithm produces a solution set consisting of different solutions instead of producing a single solution to problems. In this way, many points in the search space are evaluated at the same time, and the probability of reaching a global solution increases. The solutions in the solution set are completely independent of each other. Each is a vector on a multidimensional space. The Bees

Algorithm has some advantages compared to the other algorithms: The algorithm has local search and global search ability, implemented with several optimization problems, easy to use, available for hybridization combination with other algorithms. In addition, using the Bees Algorithm to solve the problem in this study is a diversity. In other words, it has been shown that the Bees Algorithm can be used to solve such problems.

The intervals determined for the Bees Algorithm optimization parameters are given in Table 2. These values were preferred to provide a well-built range as wide as possible to investigate the optimum points, but as narrow as possible to reach optimum point more accurate and faster by reducing the work done by algorithm. P_{gc} value's lower limit was the critical pressure of CO₂. The optimum gas cooler pressure at 46 °C which is the highest environmental temperature value, was determined with the correlation equations given in the literature [3, 39, 40], and the upper limit of P_{gc} was taken as 13000 kPa as a value above these determined values. The limitation of the intermediate pressure (P_{int}) was defined as 3500 kPa to 4500 kPa. Lower limit of P_{int} should have a higher pressure than the MT evaporator pressure. Also, there should be a difference between the upper limit of P_{int} and the condenser pressure. Another consideration for the upper limit of the P_{int} is safety in terms of preventing high pressure values within the supermarket [16]. The definition of quality necessitates that the MT evaporator outlet quality (x_{14}) can vary within the range of 0 to 1. However, the algorithm was written to prevent any liquid entering the compressors.

Table 2. Optimization parameter limits.

Parameters	Lower Limit	Upper Limit
Gas cooler pressure ($P_{gc} = P_6$)	7377 kPa	13000 kPa
Intermediate pressure ($P_{int} = P_7$)	3500 kPa	4500 kPa
MT evaporator outlet quality (x_{14})	0.00	1.00

The working procedure of BA is given in Figure 4 [26].

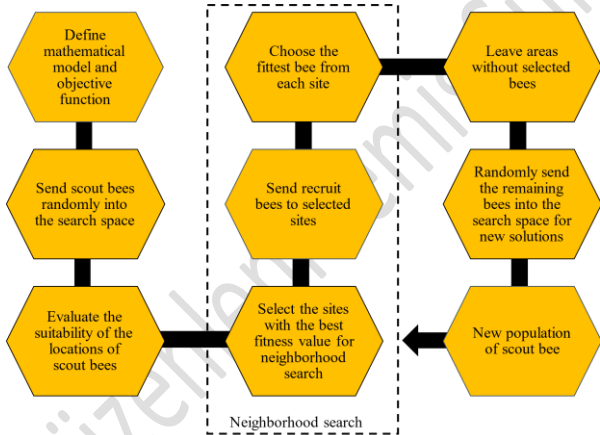

Figure 4. General procedure of the BA.

The Bees Algorithm imitates the bee dance which is a communication system within the bees to share the location and quality of the resource found with other bees. The BA consist of scout bees, best sites, elite sites, the number of bees sent to best and elite sites, and site size. These parameters were chosen as three configurations and values are given in the Table 3 [26]. More scout bees increase the probability of finding areas close to the optimum points in first iteration. Sending more bees to the best sites also helps to find optimum points inside a selected area on search space. High number of iterations may

take longer process time but increases the possibility of finding the optimum solution.

Flow chart for mathematical modeling with the Bees Algorithm optimization is given in Figure 5.

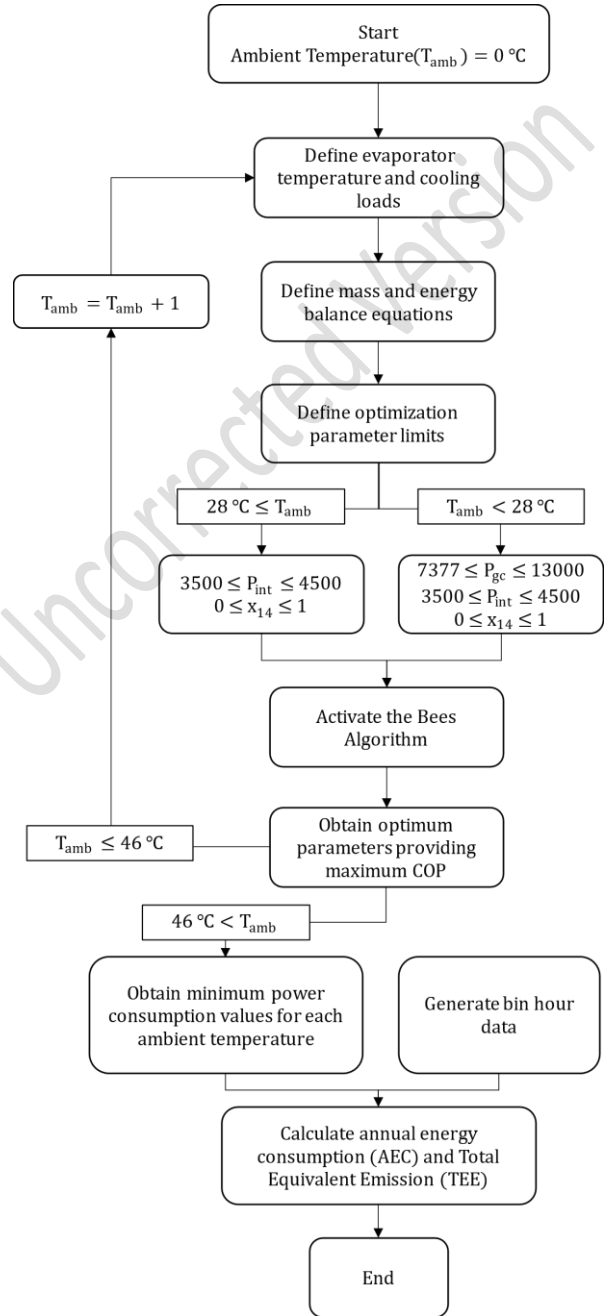

Figure 5. Flow chart for mathematical modeling with the Bees Algorithm optimization.

4 Results

Optimization results, the AEC and the TEE values are given in this chapter.

4.1 Optimization results

Three different configurations of the Bees Algorithm parameters were carried out (Table 3) to determine the maximum COP at each ambient temperature in question. The

convergence graphs for all configurations for the ambient temperature of 35 °C are given in the Figure 6-8. As seen in Figure 6-8, BA has well-converged solution for all configurations.

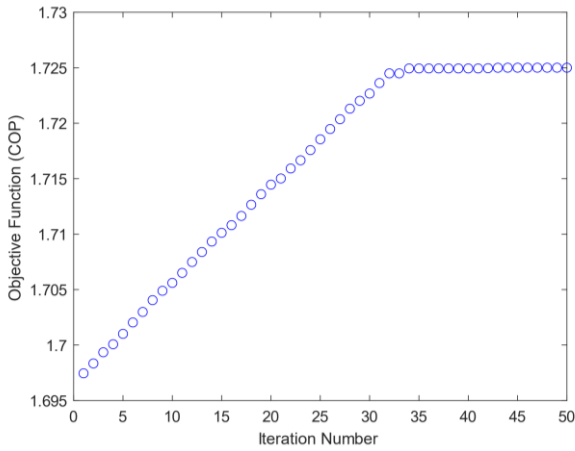

Figure 6. Convergence diagram of the Bees Algorithm for Configuration 1

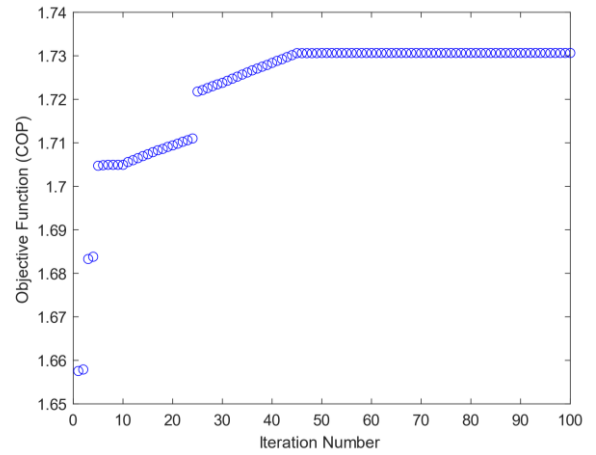

Figure 7. Convergence diagram of the Bees Algorithm for Configuration 2

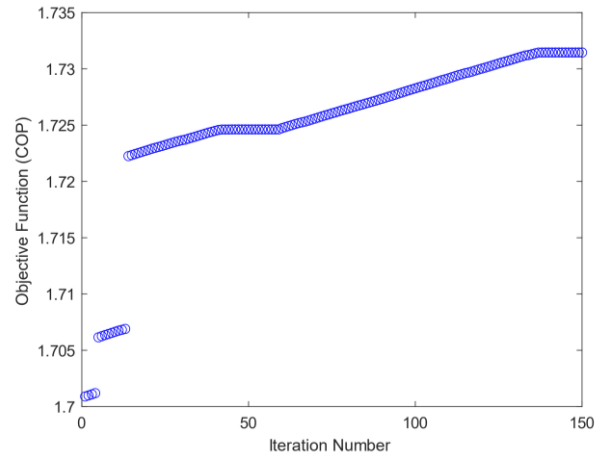

Figure 8. Convergence diagram of the Bees Algorithm for Configuration 3

Table 3. The Bees Algorithm parameters for three configurations.

The Bees Algorithm parameters	Configuration 1	Configuration 2	Configuration 3
Number of scout bees (n)	20	40	60
Number of optimal sites selected from n sites visited (m)	10	12	14
Number of elite sites in m selected sites (e)	8	10	12
Number of bees sent to the best e site (nep)	12	16	20
Number of bees sent to the remaining (m-e) site (nsp)	10	12	14
Site size (ngh)	0.01	0.005	0.001
Iteration (itr)	50	100	150

The maximum COP values were obtained by both BA and EES. These COP values and power consumptions at each ambient temperature are given in the Figure 9. The reason why the lowest ambient temperature is taken as 0 °C in the figure is that the condenser pressure does not change below 2 °C ambient temperature (Table 1). While the total power consumption of the cycle at 0 °C ambient temperature was minimum with 27.62 kW (COP 4.888), the power consumption of 198.20 kW and COP value of 1.186 were obtained at 46 °C ambient temperature.

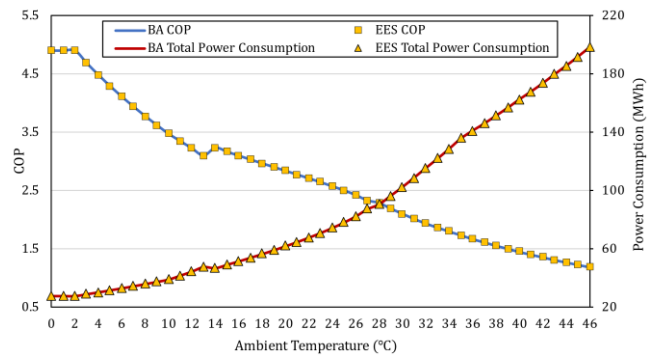

Figure 9. Optimized power consumption and COP values for each ambient temperature.

The optimum parameters for obtaining the minimum power consumption and maximum COP values given in Figure 9 are shown in Figure 10 according to the ambient temperatures. The similarity (0.10% on average) between BA and EES results demonstrates that MATLAB and COOLPROP can be used to analyze refrigeration cycles instead of EES when necessary.

As seen at Figure 10, the intermediate pressure value remained at the lower limit of 3500 kPa under 14 °C where the parallel compressor is not active. Such a result could be expected as the decrease in the intermediate pressure value means that the refrigerant going to the evaporators in LVS will have lower enthalpy and cause lower mass flow rates. However, with the activation of the parallel compressor, the optimum P_{int} was increased and was fixed about the upper limit of 4500 kPa at temperatures higher than 20 °C. This situation, which reduces the pressure ratio of the parallel compressor, reveals that the power consumption of the system is reduced. An almost linear increase can be observed between 14-20 °C temperatures.

The optimum gas cooler pressure increases in proportion to the ambient temperatures. 7626 kPa gas cooler pressure was obtained at the ambient temperature of 28 °C, which is the first point of the transcritical operation. The optimum result was 11956 kPa at the maximum ambient temperature of 46 °C. Below 28 °C condenser pressure was determined as given in Table 1.

The MT evaporator outlet quality (x_{14}) was found about 0.67 at ambient temperatures below 14 °C. Above the point that parallel compressor is activated and P_{int} tends to be 4500 kPa, optimum x_{14} was found between 0.62 and 0.65 approximately. An increase in this value with respect to ambient temperature was seen accordingly with optimum gas cooler pressure.

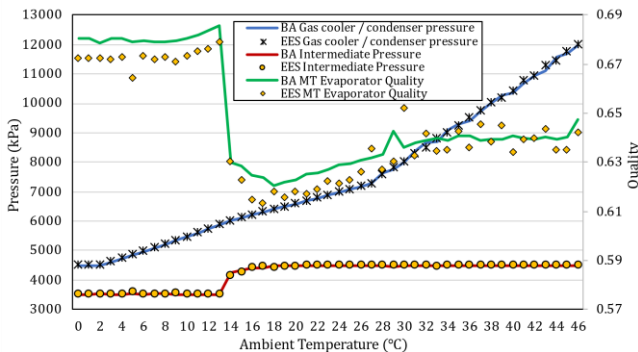

Figure 10. Optimum P_{gc} , P_{int} and x_{14} values for ambient temperatures.

Gas cooler pressure (P_{gc}) is naturally an optimization parameter. However, intermediate pressure (P_{int}) and MT evaporator outlet quality (x_{14}) can be set constant in some cases. According to this, one more optimization was made by assuming these two values are constant. P_{int} was selected on the given limits (Table 2) as 3500 kPa and 4500 kPa. x_{14} was assumed constant at values which ensures liquid does not enter any compressor on any ambient condition. Thus, x_{14} value was taken 0.701 and 0.686 for P_{int} of 3500 kPa and 4500 kPa values respectively. When only P_{gc} is optimized with constant values of P_{int} of 3500 kPa and x_{14} of 0.701, COP decreases up to 7.9% compared to the optimization of three parameters together. However, intermediate pressure of 4500 kPa and MT evaporator outlet quality of 0.686 can be preferred constant as they cause approximately same power consumption on average between 28 °C and 46 °C ambient temperatures at optimum gas

cooler pressure compared to the optimization of three parameters together.

Another comparison was made with constant P_{int} of 3500 kPa, and x_{14} of 0.95 values selected in accordance with literature [11]. Up to 8.7% energy savings are obtained by the optimization of three selected parameters in comparison with these constant P_{int} and x_{14} .

4.2 Annual energy consumption and emission results

The AEC results were calculated with the power consumption values obtained by the optimization of the three parameters and the generated climate models. Accordingly, the tropical climate had the highest AEC with 728.56 MWh, followed by arid climate (655.76 MWh), temperate climate (497.86 MWh) and continental climate (380.01 MWh) (Figure 11). Power consumption values are higher in high temperatures as shown in Figure 9. Accordingly, warmer climates which have longer times in hotter temperatures have higher AEC values than colder climates. AEC of tropical climate (A) was found 91.72% higher than continental climate (D).

CO₂ is an environmentally friendly refrigerant and its direct damage to nature is very low. Almost all of the contribution to global warming occurs by indirect contribution. Since the indirect contribution is directly proportional to the energy consumption, the TEE of the cycle for 15 years was found the highest in the tropical climate (Figure 12). Other climates follow the order obtained for AEC.

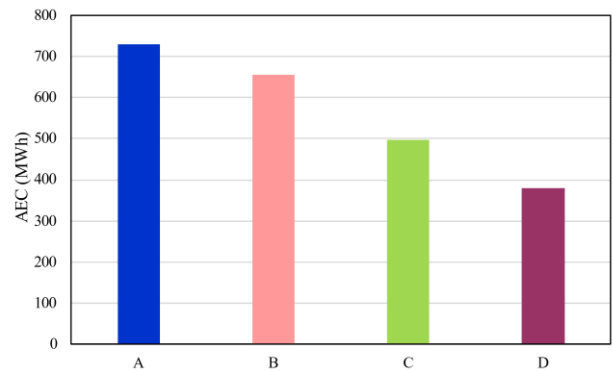

Figure 11. AEC results for climate regions.

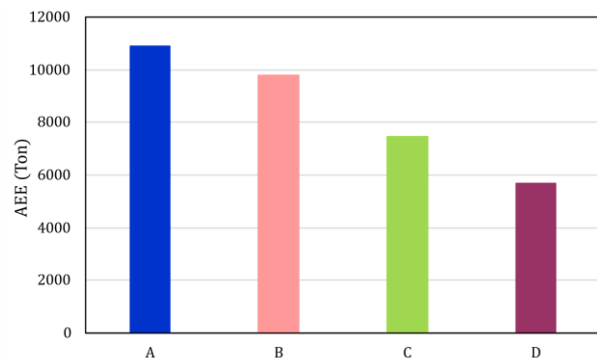

Figure 12. TEE results for climate regions.

5 Conclusion

CO₂ booster refrigeration system with flooded evaporators and parallel compressor (BFP) was chosen for the optimization. Gas cooler pressure (P_{gc}), intermediate pressure (P_{int}) and medium

temperature evaporator outlet quality (x_{14}) parameters were selected to be optimized to get the minimum power consumption (maximum COP) at ambient temperatures from 0 °C to 46 °C. The Bees Algorithm was used under three different configurations. All configurations were converged well. The AEC and 15-year TEE calculations were made. According to the optimization and analysis results;

- Intermediate pressure tends to be lower at ambient temperatures below 14 °C while it is more energy saving at higher values at ambient temperatures over 20 °C.
- Gas cooler pressure at transcritical operation is almost linearly changing with respect to ambient temperatures.
- The optimal values for x_{14} ranged between 0.62 and 0.69.
- Up to 8.7% energy savings are obtained by the optimization of three selected parameters in comparison with 3500 kPa constant intermediate pressure and MT evaporator outlet quality of 0.95.
- Gas cooler pressure should always be optimized. However, x_{14} can be taken 0.686 and P_{int} 4500 kPa constant as they present almost the same as optimized results above 28 °C ambient temperature.
- The highest AEC and TEE were obtained for tropical climate while arid, temperate and continental climate followed the order respectively.
- MATLAB and COOLPROP can be used to analyze refrigeration cycles when EES is not accessible.

6 Author contribution statements

Within the scope of this study, Author 1 contributed to the literature review, obtaining results and writing the paper. Author 2 contributed to the analysis of results and revision of the article. Author 3 contributed to the revision of the article. All authors contributed to the formation of the idea.

7 Ethics committee approval and conflict of interest statement

There is no need to obtain an ethics committee approval for the article prepared.

There is no conflict of interest with any person / institution in the article prepared.

8 References

- [1] Gullo P, Hafner A, Banasiak K. "Transcritical R744 refrigeration systems for supermarket applications: Current status and future perspectives". *International Journal of Refrigeration*, 93:269–310, 2018.
- [2] Goetzler W, Sutherland T, Rassi M, Burgos J. "Research & Development Roadmap for Next-Generation Low Global Warming Potential Refrigerants". 2014.
- [3] Kauf F. "Determination of the optimum high pressure for transcritical CO₂-refrigeration cycles". *International Journal of Thermal Sciences*, 38:325–330, 1999.
- [4] Liao SM, Zhao TS, Jakobsen A. "A correlation of optimal heat rejection pressures in transcritical carbon dioxide cycles". *Applied Thermal Engineering*, 2000.
- [5] Yang L, Li H, Cai SW, Shao LL, Zhang CL. "Minimizing COP loss from optimal high pressure correlation for transcritical CO₂ cycle". *Applied Thermal Engineering*, 89:656–662, 2015.
- [6] European Commission. "Development and demonstration of a prototype transcritical CO₂ refrigeration system Final Report". 2008.
- [7] Ge YT, Tassou SA. "Thermodynamic analysis of transcritical CO₂ booster refrigeration systems in supermarket". *Energy Conversion and Management*, 52:1868–1875, 2011.
- [8] Mylona Z, Kolokotroni M, Tsamos KM, Tassou SA. "Comparative analysis on the energy use and environmental impact of different refrigeration systems for frozen food supermarket application". *Energy Procedia*, 121–130, 2017.
- [9] Amaris C, Tsamos KM, Tassou SA. "Analysis of an R744 typical booster configuration, an R744 parallel-compressor booster configuration and an R717/R744 cascade refrigeration system for retail food applications. Part 1: Thermodynamic analysis". *Energy Procedia*, 259–267, 2019.
- [10] Lata M, Purohit N, Gupta DK. "Techno-economic assessment of trans-critical CO₂ booster system with modified evaporative cooling for supermarket application in Indian context". *Environmental Progress & Sustainable Energy*, 40, 2021.
- [11] Cui Q, Gao E, Zhang Z, Zhang X. "Preliminary study on the feasibility assessment of CO₂ booster refrigeration systems for supermarket application in China: An energetic, economic, and environmental analysis". *Energy Conversion and Management*, 225, 2020.
- [12] Karampour M, Sawalha S. "State-of-the-art integrated CO₂ refrigeration system for supermarkets: A comparative analysis". *International Journal of Refrigeration*, 86:239–257, 2018.
- [13] Sooben D, Purohit N, Mohee R, Meunier F, Dasgupta MS. "R744 refrigeration as an alternative for the supermarket sector in small tropical island developing states: The case of Mauritius". *International Journal of Refrigeration*, 103:264–273, 2019.
- [14] Lata M, Gupta DK. "Performance evaluation and comparative analysis of trans-critical CO₂ booster refrigeration systems with modified evaporative cooled gas cooler for supermarket application in Indian context". *International Journal of Refrigeration*, 120:248–259, 2020.
- [15] Mitsopoulos G, Syngounas E, Tsimpoukis D, Bellos E, Tzivanidis C, Anagnostatos S. "Annual performance of a supermarket refrigeration system using different configurations with CO₂ refrigerant". *Energy Conversion and Management*: X 1, 2019.
- [16] Gullo P, Cortella G, Minetto S, Polzot A. "Overfed evaporators and parallel compression in commercial R744 booster refrigeration systems - An assessment of energy benefits". *Refrigeration Science and Technology*, 261–268, 2016.
- [17] Sun Z, Li J, Liang Y, Sun H, Liu S, Yang L, Wang C, Dai B. "Performance assessment of CO₂ supermarket refrigeration system in different climate zones of China". *Energy Conversion and Management*, 208, 2020.
- [18] Sacasas D, Vega J, Cuevas C. "An annual energetic evaluation of booster and parallel refrigeration systems with

R744 in food retail supermarkets. A Chilean perspective". *International Journal of Refrigeration*, 133:326–336, 2022.

[19] Isik M, Bilir Sag N "Energetic, economic, and environmental analysis of CO₂ booster refrigeration systems of supermarket application for Türkiye". *Sadhana*, 2023.

[20] Deymi-Dashtebayaz M, Sulin A, Ryabova T, Sankina I, Farahnak M, Nazeri R. "Energy, exergoeconomic and environmental optimization of a cascade refrigeration system using different low GWP refrigerants". *Journal of Environmental Chemical Engineering*, 9, 2021.

[21] Sun Y, Wang J, Xie J. "Performance optimizations of the transcritical CO₂ two-stage compression refrigeration system and influences of the auxiliary gas cooler". *Energies*, 14, 2021.

[22] Citarella B, Viscito L, Mochizuki K, Mauro AW. "Multi-criteria (thermo-economic) optimization and environmental analysis of a food refrigeration system working with low environmental impact refrigerants". *Energy Conversion and Management*, 253, 2022.

[23] Ge YT, Tassou SA, Santosa ID, Tsamos K. "Design optimisation of CO₂ gas cooler/condenser in a refrigeration system". *Applied Energy*, 160:973–981, 2015.

[24] Liu G, Zhao H, Wang Z, Abdulwahid AA, Han J. "Performance Study and Multi-Objective Optimization of a Two-Temperature CO₂ Refrigeration System with Economizer Based on Energetic, Exergetic and Economic Analysis". *Journal of Thermal Science*, 31:1416–1433, 2022.

[25] Ahmed R, Mahadzir S, Erniza B Rozali N, Biswas K, Matovu F, Ahmed K. "Artificial intelligence techniques in refrigeration system modelling and optimization: A multi-disciplinary review". *Sustainable Energy Technologies and Assessments*, 47, 2021.

[26] Unal RE, Guzel MH, Sen MA, Kose F, Kalyoncu M. "Investigation on the cost-effective optimal dimensions of a solar chimney with the Bees Algorithm". *International Journal of Energy and Environmental Engineering*, 2022.

[27] Fahmy AA, Kalyoncu M, Castellani M. "Automatic design of control systems for robot manipulators using the bees algorithm". *Proceedings of the Institution of Mechanical Engineers Part I: Journal of Systems and Control Engineering*, 226:497–508, 2012.

[28] Fahmy AA. "Using the Bees Algorithm to select the optimal speed parameters for wind turbine generators". *Journal of King Saud University - Computer and Information Sciences*, 24:17–26, 2012.

[29] Banooni S, Zarea H, Molana M. "Thermodynamic and Economic Optimization of Plate Fin Heat Exchangers Using the Bees Algorithm". *Heat Transfer - Asian Research*, 43:427–446, 2014.

[30] Pham DT, Kalyoncu M. "Optimisation of a fuzzy logic controller for a flexible single-link robot arm using the bees algorithm", *IEEE International Conference on Industrial Informatic*, 475–480, 2009.

[31] *Engineering Equation Solver*, 2023.

[32] *Mathworks, MATLAB (R2021a)*, 2023.

[33] Beck HE, Zimmermann NE, McVicar TR, Vergopolan N, Berg A, Wood EF. "Present and future Köppen-geiger climate classification maps at 1-km resolution". *Scientific Data*, 5, 2018.

[34] Gullo P. "Innovative fully integrated transcritical R744 refrigeration systems for a HFC-free future of supermarkets in warm and hot climates". *International Journal of Refrigeration*, 108:283–310, 2019.

[35] *Turkish State Meteorological Service, Meteorological Data*, 2021.

[36] Purohit N, Gupta DK, Dasgupta MS. "Energetic and economic analysis of trans-critical CO₂ booster system for refrigeration in warm climatic condition". *International Journal of Refrigeration* 80:182–196, 2017.

[37] Gullo P, Tsamos K, Hafner A, Ge Y, Tassou SA. "State-of-the-art technologies for transcritical R744 refrigeration systems - A theoretical assessment of energy advantages for European food retail industry", *Energy Procedia*, 46–53, 2017.

[38] Bell IH, Wronski J, Quoilin S, Lemort V. "Pure and pseudo-pure fluid thermophysical property evaluation and the open-source thermophysical property library coolprop". *Industrial & Engineering Chemistry Research*, 53:2498–2508, 2014.

[39] Chen Y, Gu J. "The optimum high pressure for CO₂ transcritical refrigeration systems with internal heat exchangers". *International Journal of Refrigeration*, 28:1238–1249, 2005.

[40] Qi PC, He YL, Wang XL, Meng XZ. "Experimental investigation of the optimal heat rejection pressure for a transcritical CO₂ heat pump water heater". *Applied Thermal Engineering*, 56:120–125, 2013.