

# A new multi-input single-output voltage-mode universal biquadratic filter with grounded passive elements and orthogonally adjustable filter parameters

## Topraklanmış pasif elemanlar ve dikey olarak ayarlanabilir filtre parametrelerine sahip yeni bir çok-girişli tek-çıkışlı gerilim modlu evrensel bikuadratik filtre

Elham MİNAYI<sup>1\*</sup>

<sup>1</sup>Department of Engineering, Dogus University, İstanbul, Turkey.  
eminayi@dogus.edu.tr

Received/Geliş Tarihi: 10.05.2024  
Accepted/Kabul Tarihi: 14.10.2024

Revision/Düzeltilme Tarihi: 25.09.2024

doi: 10.5505/pajes.2024.88935  
Research Article/Araştırma Makalesi

### Abstract

A novel multiple-input, single-output (MISO) Voltage-Mode (VM) analog filter configuration composed of two plus-type differential voltage current conveyors (DVCC+) as active components moreover two capacitors and three resistors as passive elements is proposed in this paper. By selecting input voltage nodes in different orders, it is able to provide all five standard second-order filter responses in one topology. Also, it does not need any passive element matching condition; so the proposed filter is suitable for integrated circuit (IC) design. Further, it offers orthogonal control of quality factor ( $Q$ ) and angular frequency ( $\omega_0$ ), can be adjusted electronically. Further, to confirm the theoretical analysis, simulation results are investigated. TSMC 0.13  $\mu\text{m}$  process parameters is applied to the circuit and voltage sources are selected as  $\pm 0.75\text{ V}$  and  $0.2\text{ V}$  for  $V_B$ , in this case the power consumption is found as  $0.65\text{ mW}$ .

**Keywords:** DVCC+, Analog Filter, Voltage-mode, Multiple Input-Single Output Filter, Universal biquadratic filter

### Öz

Bu çalışmada, yalnızca iki artı tipli gerilim farkı alan akım taşıyıcı (DVCC+), iki kapasitör ve üç direnç kullanarak, tek bir topolojide ikinci derece filtrenin standart beş farklı tepkisinin tamamını sağlayabilecek çok girişli, tek çıkışlı gerilim modlu evrensel biquadratic filtre devresi önerilmiştir. Önerilen devre, pasif eleman eşleştirme şartından bağımsızdır. Bu nedenle, Entegre Devre Teknolojisi (IC) için uygundur. Ayrıca, kalite faktörü ( $Q$ ) ve açısal frekansın ( $\omega_0$ ) dikey olarak kontrol edilmesi mümkün olup, elektronik olarak ayarlanabilir. Teorik analizleri doğrulamak için PSPICE simülasyon sonuçları incelenmiştir.

**Anahtar kelimeler:** DVCC+, Analog Filtre, Gerilim-Modlu, Çok Girişli-tek çıkışlı Filtre, Evrensel Bikuadratik Filtre

## 1 Introduction

Analog filters are widely utilized for applications like as continuous-time analog signal processing, communication systems, signal generators, as well as in measurement instrumentations, power electronic, and control systems [1-3].

According to the feature of transferring the desired range of frequency from input to the output, analog filters are extensively used in signal processing. In a multiple-input, single-output (MISO) second-order universal filter, several output responses of the filter can be attained easily by properly selecting the input voltage source(s). Also, this selection can be applied digitally to the circuit by employing a microcontroller or microcomputer. Numerous universal Voltage-Mode (VM) filter implementations have been presented in [3-24]. However, many of them have the following disadvantages:

- I. lack of orthogonally control of central frequency ( $\omega_0$ ) and quality factor ( $Q$ ) [3, 7, 12, 15, 21, 22].
- II. All conventional second-order functions, cannot be obtained in one circuit topology [11].

- III. Capacitor connection to the  $X$  terminal of the active element, which cause restrictions at high frequencies [8-10].
- IV. Redundant number of active devices [8, 11, 17, 21, 22].
- V. Employing excessive number of passive components [8].
- VI. Requirement for floating capacitor(s), these circuits are not suitable for IC design [9, 10, 20]. According to using only grounded capacitors in the structure of proposed LP and BP filters, these topologies are suitable for IC technology implementations.
- VII. Requirement of matching condition for obtaining All pass filter [13, 23, 24].

A novel plus-type differential voltage current conveyors (DVCC+) based MISO universal biquadratic filter is presented in this work. The recently proposed filter performs all conventional second-order responses, namely Low-Pass (LP), High-Pass (HP), Band-Pass (BP), Band-Stop (BS) and All-Pass (AP) in only one circuit topology. In the structure of the filter two DVCC+s, two capacitors and three resistors are employed. The proposed filter does not require any component matching

\*Corresponding author/Yazışılan Yazar

condition. Also, the angular frequency ( $\omega_0$ ) and quality factor ( $Q$ ) parameters can be adjusted orthogonally.

This article proceeds in the following order: a brief introduction is given in Section 1, the newly designed second-order VM universal filter with its mathematical descriptions, calculated  $\omega_0$  and  $Q$  and passive component sensitivity analysis are given in Section 2. In Section 3, the effects of non-idealities on transfer functions are investigated. In Section 4, to verify the performance of proposed filter some simulation outcomes are given. Finally, Section 5 brings the paper to a close.

## 2 Proposed voltage mode filter

The schematic block diagram and the non-ideal ports definition of DVCC+ are given in Fig. 1 and (1) respectively,

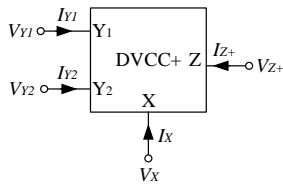

Figure 1. The schematic block diagram of DVCC+

$$\begin{bmatrix} I_{Y1} \\ I_{Y2} \\ V_X \\ I_{Z+} \end{bmatrix} = \begin{bmatrix} 0 & 0 & 0 \\ 0 & 0 & 0 \\ \alpha & -\beta & 0 \\ 0 & 0 & \gamma \end{bmatrix} \begin{bmatrix} V_{Y1} \\ V_{Y2} \\ I_X \end{bmatrix} \quad (1)$$

In (1),  $\alpha$ ,  $\gamma$  and  $\beta$  are the non-ideal current and voltage gains.

The non-ideal current and voltage gains are expressed in (2-4),

$$\alpha(s) = \frac{\alpha_0}{1 + \frac{s}{\omega_\alpha}} \quad (2)$$

$$\beta(s) = \frac{\beta_0}{1 + \frac{s}{\omega_\beta}} \quad (3)$$

$$\gamma(s) = \frac{\gamma_0}{1 + \frac{s}{\omega_\gamma}} \quad (4)$$

$\omega_\alpha$ ,  $\omega_\beta$  and  $\omega_\gamma$  parameters are ideally infinity.  $\alpha_0$ ,  $\beta_0$  and  $\gamma_0$  are DC gains and ideally are equal to unity.

In non-ideal cases DC gains are expressed in (5-7),

$$\alpha_0 = 1 + \varepsilon_\alpha \quad (5)$$

$$\beta_0 = 1 + \varepsilon_\beta \quad (6)$$

$$\gamma_0 = 1 + \varepsilon_\gamma \quad (7)$$

$\varepsilon_\alpha$ ,  $\varepsilon_\beta$  and  $\varepsilon_\gamma$  are tracking errors which are defined as  $|\varepsilon_\alpha| \ll 1$ ,  $|\varepsilon_\beta| \ll 1$  and  $|\varepsilon_\gamma| \ll 1$ . So in ideal case the  $\alpha$ ,  $\beta$  and  $\gamma$  coefficients are equal to unity and the ideal definition of DVCC+ becomes as,

$$\begin{bmatrix} I_{Y1} \\ I_{Y2} \\ V_X \\ I_{Z+} \end{bmatrix} = \begin{bmatrix} 0 & 0 & 0 \\ 0 & 0 & 0 \\ 1 & -1 & 0 \\ 0 & 0 & 1 \end{bmatrix} \begin{bmatrix} V_{Y1} \\ V_{Y2} \\ I_X \end{bmatrix} \quad (8)$$

The newly recommended MISO voltage mode biquadratic universal filter configuration is depicted in Fig. 2.

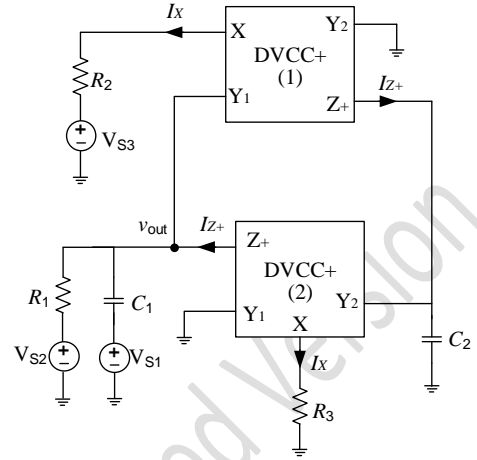

Figure 2. Proposed DVCC+ based MISO universal biquadratic filter

The output voltage ( $V_{out}$ ) in terms of input voltages  $V_{S1}$ ,  $V_{S2}$ , and  $V_{S3}$  is,

$$V_{out}(s) = \frac{s^2 C_1 C_2 R_1 R_2 R_3 V_{S1} + s C_2 R_3 R_2 V_{S2} + R_1 V_{S3}}{s^2 C_1 C_2 R_1 R_2 R_3 + s C_2 R_3 R_2 + R_1} \quad (9)$$

As shown in Table 1, by properly selection of different voltage source(s), various filter functions will be achieved. The realization of five conventional filter functions can be expressed as demonstrated in Table 2.

Table 1. Filter types according to the selection of source(s)

Realization	$V_{S1}$	$V_{S2}$	$V_{S3}$	Filter Type
# I	$V_{in}$	0	0	High-Pass
# II	0	0	$V_{in}$	Low-Pass
# III	0	$V_{in}$	0	Band-Pass
# IV	$V_{in}$	0	$V_{in}$	Band-Stop
# V	$V_{in}$	$-V_{in}$	$V_{in}$	All-Pass

Table 2. Transfer functions of different filter types

Transfer Function of Filter	Filter Type
$\frac{s^2 C_1 C_2 R_1 R_2 R_3}{s^2 C_1 C_2 R_1 R_2 R_3 + s C_2 R_2 R_3 + R_1}$	High-Pass
$\frac{R_1}{s^2 C_1 C_2 R_1 R_2 R_3 + s C_2 R_2 R_3 + R_1}$	Low-Pass
$\frac{s C_2 R_3 R_2}{s^2 C_1 C_2 R_1 R_2 R_3 + s C_2 R_2 R_3 + R_1}$	Band-Pass
$\frac{s^2 C_1 C_2 R_1 R_2 R_3 + R_1}{s^2 C_1 C_2 R_1 R_2 R_3 + s C_2 R_2 R_3 + R_1}$	Band-Stop
$\frac{s^2 C_1 C_2 R_1 R_2 R_3 - s C_2 R_2 R_3 + R_1}{s^2 C_1 C_2 R_1 R_2 R_3 + s C_2 R_2 R_3 + R_1}$	All-Pass

According to (9), filter parameters  $\omega_0$  and  $Q$  are found as (10-11).

$$\omega_0 = \frac{1}{\sqrt{C_1 C_2 R_2 R_3}} \quad (10)$$

$$Q = R_1 \sqrt{\frac{C_1}{C_2 R_2 R_3}} \quad (11)$$

The Band-Width ( $BW$ ) of the filters is calculated as,

$$BW = \frac{\omega_0}{Q} = \frac{1}{R_1 C_1} \quad (12)$$

From (10) and (11) it can be easily understanding that the  $Q$  can be set, through resistor  $R_1$ , without influencing  $\omega_0$ . So,  $Q$  and  $\omega_0$  parameters are orthogonal and the filters are biquadratic filters. In the special case,  $C_1 = C_2 = C$ ,  $R_1 = R_2 = R_3 = R$  the  $\omega_0 = \frac{1}{RC}$  and  $Q=1$ .

The ideal passive component sensitivities of  $\omega_0$ ,  $Q$  and  $BW$  are found as,

$$S_{R_2, R_3}^{\omega_0} = S_{C_1, C_2}^{\omega_0} = -\frac{1}{2} \quad (13)$$

$$S_{R_1}^Q = 1, S_{R_2, R_3, C_2}^Q = -S_{C_1}^Q = -\frac{1}{2} \quad (14)$$

$$S_{R_1}^{BW} = S_{C_1}^{BW} = -1 \quad (15)$$

By performing a simple inspection in (13-15) it can be concluded that as magnitude of sensitivities are less than one, the proposed topology has suitable performance in term of passive component changing.

### 3 Effect of non-ideal DVCC+

According to (1) with regard to the non-ideal gains of the DVCC+s in proposed filter, the general transfer function in (9) turns to,

$$V_{out}(s) = \frac{s^2 C_1 C_2 R_1 R_2 R_3 V_{s1} + s C_2 R_2 R_3 V_{s2} + \alpha_1 \beta_2 \gamma_1 \gamma_2 R_1 V_{s3}}{s^2 C_1 C_2 R_1 R_2 R_3 + s C_2 R_2 R_3 + \alpha_1 \beta_2 \gamma_1 \gamma_2 R_1} \quad (16)$$

In non-ideal case the  $\omega_0$  and  $Q$  are calculated as,

$$\omega_0 = \sqrt{\frac{\alpha_1 \beta_2 \gamma_1 \gamma_2}{C_1 C_2 R_2 R_3}} \quad (17)$$

$$Q = R_1 \sqrt{\frac{\alpha_1 \beta_2 \gamma_1 \gamma_2 C_1}{C_2 R_2 R_3}} \quad (18)$$

The transfer functions of all types of filters in non-ideal case are demonstrated in Table 3.

According to Table 3, it can be easily seen that non-ideal gains are shaped as multiplier for only one of the coefficients of the transfer functions.

In this case the passive component sensitivities can be found as,

$$S_{\alpha_1, \gamma_1, \gamma_2, \beta_2}^{\omega_0} = -S_{C_1, C_2, R_2, R_3}^{\omega_0} = \frac{1}{2} \quad (19)$$

$$S_{R_1}^Q = 1, S_{\alpha_1, \beta_2, \gamma_1, \gamma_2, C_1}^Q = -S_{C_2, R_2, R_3}^Q = \frac{1}{2} \quad (20)$$

Table 3. Transfer functions of different filter types in non-ideal case

Transfer Function of Filter	Filter Type
$\frac{s^2 C_1 C_2 R_1 R_2 R_3}{s^2 C_1 C_2 R_1 R_2 R_3 + s C_2 R_2 R_3 + \alpha_1 \beta_2 \gamma_1 \gamma_2 R_1}$	High-Pass
$\frac{\alpha_1 \beta_2 \gamma_1 \gamma_2 R_1}{s^2 C_1 C_2 R_1 R_2 R_3 + s C_2 R_2 R_3 + \alpha_1 \beta_2 \gamma_1 \gamma_2 R_1}$	Low-Pass
$\frac{s C_2 R_2 R_3}{s^2 C_1 C_2 R_1 R_2 R_3 + s C_2 R_2 R_3 + \alpha_1 \beta_2 \gamma_1 \gamma_2 R_1}$	Band-Pass
$\frac{s^2 C_1 C_2 R_1 R_2 R_3 + \alpha_1 \beta_2 \gamma_1 \gamma_2 R_1}{s^2 C_1 C_2 R_1 R_2 R_3 + s C_2 R_2 R_3 + \alpha_1 \beta_2 \gamma_1 \gamma_2 R_1}$	Band-Stop
$\frac{s^2 C_1 C_2 R_1 R_2 R_3 - s C_2 R_2 R_3 + \alpha_1 \beta_2 \gamma_1 \gamma_2 R_1}{s^2 C_1 C_2 R_1 R_2 R_3 + s C_2 R_2 R_3 + \alpha_1 \beta_2 \gamma_1 \gamma_2 R_1}$	All-Pass

### 4 Simulation results of the universal filter

In this part the simulation outcomes of the recommended VM biquadratic universal filter are exposed. The simulations are done by applying an AC voltage source with amplitude of 1V to all inputs of the filters according to Table 3. Capacitors and resistors are chosen as  $C_1 = C_2 = 100$  pF and  $R_1 = R_2 = R_3 = 400\Omega$ . In this situation, the center frequency ( $f_0$ ) and  $Q$  of filters are calculated as  $f_0 = \frac{\omega_0}{2\pi} \cong 3,98$  MHz and  $Q=1$ .

For DVCC+s, the transistor-based circuit is given in Fig. 3 with 0.13  $\mu\text{m}$  CMOS technology and aspect ratio values given in Table 4. is being used. The input stage of DVCC+ is realized with two differential stages ( $M_5$ - $M_6$  and  $M_7$ - $M_8$ ) with active load  $M_9$ - $M_{10}$ . The second stage applying negative feedback from the output node (drain of  $M_7$ ) to the terminal X is composed of  $M_{11}$ . The current through the terminal X is conveyed to the Z terminal with the help of transistors  $M_3$ - $M_4$ , and  $M_{11}$ - $M_{12}$ . It can be easily seen that  $I_X$  and  $I_Z$  flow in the same direction towards or away from the DVCC+. The applied voltage sources are selected as  $\pm 0.75$  V and the  $V_B$  is chosen as 0.2 V.

Figure 3. CMOS realization of DVCC+ [19]

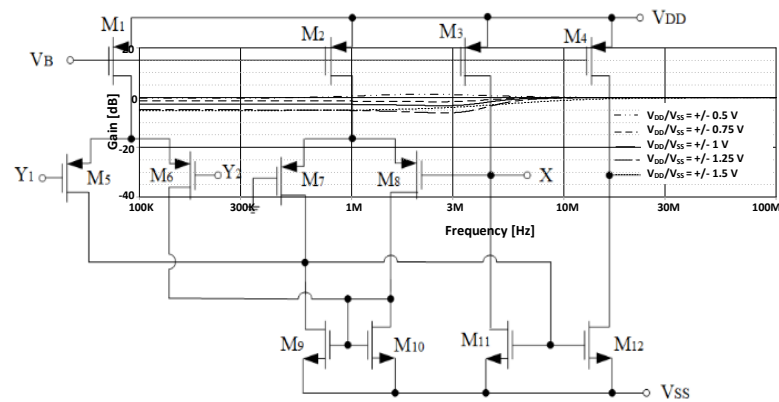

Table 4. Aspect ratio of transistors in Fig. 3

PMOS transistors	$W(\mu\text{m})/L(\mu\text{m})$
$M_1 - M_8$	39 / 0.39

NMOS transistors	$W(\mu m)/L(\mu m)$
$M_9 - M_{12}$	13 / 0.39

For examining the functionality of the proposed filter all of the realizations in Table 1 are applied to the proposed circuit. Realizations #1, #2 and #3 are applied to the proposed circuit and the obtained gain characteristics of HP, LP and BP in terms of frequency are shown in Fig. 4.

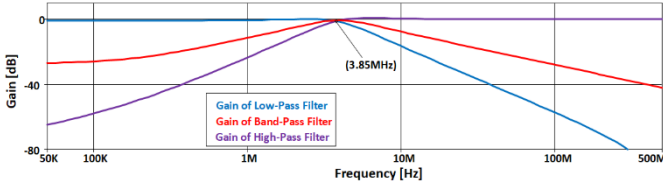

Figure 4. Gain characteristics of HP, LP and BP filters versus frequency

Realization #4 is applied to the proposed circuit and the obtained AC response of BS filter with respect to frequency is demonstrated in Fig. 5.

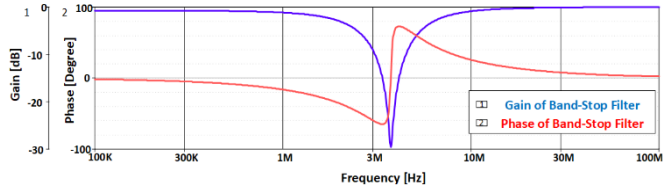

Figure 5. Characteristics of BS filter versus frequency

Realization #5 is applied to the proposed circuit and the obtained AC response of AP filter with respect to frequency is demonstrated in Fig. 6, in this case the obtained gain for all frequencies is approximately equal to 0 dB.

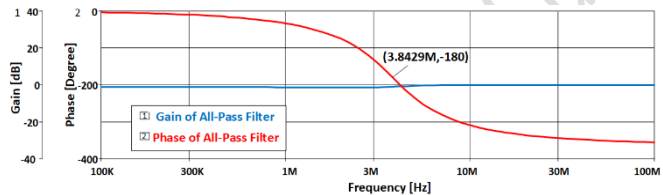

Figure 6. Characteristics of AP filter versus frequency

The process, voltage, and temperature (PVT) analysis is also applied to AP filter. The variation of  $f_0$  for gain characteristic with respect to different values of  $V_{DD}$  and  $V_{SS}$  are given in Fig. 7. By investigating the  $f_0$  and gain variation of AP filter with respect to  $V_{DD}$  and  $V_{SS}$ , one can understand that the voltages between 0.5V and 1.5V are acceptable voltage ranges for good operation of newly proposed VM filter.

Figure 7. Variation of  $f_0$  for gain characteristic with respect to different values of  $V_{DD}$  and  $V_{SS}$

The temperature analysis applied to AP filter. The variation of  $f_0$  for gain characteristics with respect to temperature are given in Fig. 8.

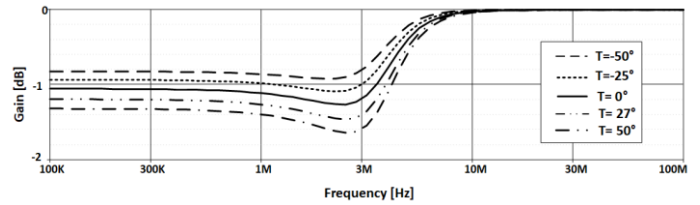

Figure 8. Gain characteristic variation of all-pass filter with respect to temperature

By investigating the variation in gain characteristic of AP filter with respect to temperature, one can understand that the newly designed circuit is durable to temperature changing and exhibits negligible deviation in results. The newly designed filter is compared with previously DVCC based universal filters in Table 5.

## 5 Conclusion

A newly designed inductor-less MISO-VM universal biquadratic filter configuration, using two DVCC+s, two capacitors, and three resistors is introduced in this article. The advantages of designed filter are as following:

- Is able to provide simultaneously all conventional VM filter responses by applying the appropriate input(s) to the proposed circuit without requiring any passive element matching conditions.
- Is able to adjust  $Q$  from  $\omega_0$  independently by selecting different values for  $R_I$  only, which is valuable superiority due to tuning flexibility in different applications.
- In cases of LP and BP it consists of only grounded capacitors; therefore, it is appropriate for IC technology implementation.
- The designed filter very low sensitivity to all active and passive components.

The feasibility of the recommended filter has been examined by applying PSPICE simulations and found that, the simulation and theoretical results match well. Also, applying PVT and temperature analysis proved that the proposed VM filter has a good performance with respect to voltage sources and temperature variation.

Table 5. A comparison between DVCC+ based universal filters

Features	Proposed	[22] Fig 4	[21] Fig 2	[21] Fig 3	[23]	[24] Fig 2	[24] Fig 3
Number of DVCC(s)	2	3	3	3	3	2	2
CMOS Realization ( $\mu m$ )	0.13	0.18	0.13	0.13	0.25	0.13	0.13
Number of passive devices	2C, 3R	2C, 4R	2C, 2R	2C, 2R	2C, 3R	2C, 4R	2C, 4R

Type of filter	MISO	SIMO	SIMO	SIMO	SIMO	SIMO	SIMO
Orthogonal control of $\omega_0$ and $Q$	Yes	No	No	No	Yes	Yes	Yes
All passive devices grounded	No	Yes	Yes	No	No	No	No
Matching condition (s)	No	No	No	No	Yes	Yes	Yes
Power supply (V)	$\pm 0.75$	$\pm 1.25$	$\pm 0.75$	$\pm 0.75$	$\pm 1.25$	$\pm 0.75$	$\pm 0.75$
Power dissipation (mW)	0.65	8.47	4.36	4.36	NA	1.25	1.26

## 6 Author contribution statement

In this article the Author 1 contributed to the stages of structure, introduction, materials and methods and general evaluation of the results.

## 7 Ethics committee approval and conflict of interest statement

There is no need to obtain permission from the ethics committee for the article prepared.

There is no conflict of interest with any person / institution in the article prepared.

## 8 References

- [1] Elwan HO, Soliman AM. "Novel CMOS Differential Voltage Current Conveyor and Its Applications". *IEE Proc. Circuits Devices Syst.*, 144(3), 195-200, 1997.
- [2] Winder S. *Analog and digital filter design*. 2nd ed. Oxford, Newnes, 2002.
- [3] Chen HP, Shen SS, Wang JP. "Electronically tunable versatile voltage-mode universal filter". *AEU-International Journal of Electronics and Communications*, vol. 62, 316-319, 2008.
- [4] Klungtong S, Thanapatay D, Jaikla W. "Three-input single output voltage-mode multifunction filter with electronic controllability based on single commercially available IC". *Active and Passive Electronic Components*, vol. 2017, 5240751, 2017.
- [5] Lee CN. "Multiple-mode OTA-C universal biquad filters". *Circuits, Systems & Signal Processing*, vol. 29, 263-274, 2010.
- [6] Sangyaem S, Siripongdee S, Jaikla W, Khateb F. "Five-inputs single-output voltage mode universal filter with high input and low output impedance using VDDAs". *Optik*, vol. 128, 14-25, 2017.
- [7] Siripruchyanun M, Jaikla W. "Electronically controllable current mode universal biquad filter using single DO-CCCDTA". *Circuits, Systems & Signal Processing*, vol. 27, 113-122, 2008.
- [8] Pitaksuttayaprot K, Ritnathikul S, Jaikla W. "Voltage-Mode Biquad Multifunction Filter Using VCII's". *International Symposium on Intelligent Signal Processing and Communication Systems (ISPACS)*, Penang, Malaysia, November 22-25, 2022.
- [9] Pimpol J, Channumsin O, Tangsrirat W. "MISO Universal Filter Employing Single VDTA". *International Conference on Engineering, Applied Sciences, and Technology (ICEAST)*, Phuket, Thailand, July 4-7, 2018.
- [10] Suwanjan P, Siripongdee S, Jaikla W. "Three-Inputs Single-Output Voltage-Mode Universal Filter with Orthogonal Control Using Single Commercially Available IC". *European Conference on Electrical Engineering and Computer Science (EECS)*, Bern, Switzerland, November 17-19, 2017.
- [11] Knobob B, Suksaibul p, Kumngern M. "Five-Input One-Output Universal Filter Using Simple CMOS OTAs". *4th International Conference on Electrical, Electronics and System Engineering (ICEESE)*, Kuala Lumpur, Malaysia, November 8-9, 2018.
- [12] Raj A, Kumar P, Bhaskar DR. "Multiple-Input Single-Output Universal Biquad Filters Using Reduced Number of OTAs". *International Symposium on Advanced Electrical and Communication Technologies (ISAECT)*, Rome, Italy, November 27-29, 2019.
- [13] Komal, Kumar R, Pushkar T. "Electronically Controllable Multiple Input Single Output Universal Filter Employing OTAs". *2022 8th International Conference on Signal Processing and Communication (ICSC)*, Noida, India, December 1-3, 2022.
- [14] Roongmuanpha N, Pukkalanun T, Tangsrirat W. "Three-Input One-Output Voltage-Mode Biquadratic Filter Using Single VDBA". *8th International Electrical Engineering Congress (IEECON)*, Chiang Mai, Thailand, March 4-6, 2020.
- [15] Saxena D, Nizamuddin M. "Versatile VM Universal Biquad Filter Employing OTAs and Its Application". *10th International Conference on Signal Processing and Integrated Networks (SPIN)*, Noida, India, March 23-24, 2023.
- [16] Kumngern M, Khateb F, Kulej T. "0.5 V Universal Filter and Quadrature Oscillator Based on Multiple-Input DDTA". *IEEE Access*, vol. 11, 9957-9966, 2023.
- [17] Kumngern M, Khateb F, Kulej T, Psychalinos C. "Multiple-Input Universal Filter and Quadrature Oscillator Using Multiple-Input Operational Transconductance Amplifiers". *IEEE Access*, vol. 9, 56253-56263, 2021.
- [18] Yuce E. "Voltage-mode multifunction filters employing a single DVCC and grounded capacitors". *IEEE Transactions on Instrumentation and Measurement*, 58(7), 2216-2221, 2009.
- [19] Chiu W, Liu SI, Tsao HW, Chen JJ. "CMOS differential difference current conveyors and their applications". *IEE Proceeding Circuits, Devices and Systems*, 143(2), 91-96, 1996.
- [20] Minayi E, Goknar IC. "CIM a Current Inverting Metamutator and its Application to Universal Filters Among Others". *International Conference on Telecommunications and Signal Processing (TSP 2017)*, Barcelona, Spain, July 5-7, 2017.
- [21] Alparslan H, Yuce E. "DVCC+ based multifunction and universal filters with the high input impedance features". *Analog Integrated Circuits and Signal Processing*, 103(2), 325-335, 2020.
- [22] Unuk T, Yuce E. "A Mixed-Mode filter with DVCCs and grounded passive components only". *AEU - International Journal of Electronics and Communications*, vol. 144, 154063, 2022.
- [23] Chiu WY, Horng JW, Lee H, Huang CC. "DVCC-Based Voltage-Mode Biquadratic Filter with High-Input Impedance". *IEEE International Symposium on Electronic Design, Test & Applications*, Ho Chi Minh City, Vietnam, January 13-15, 2010.
- [24] Abaci A, Yuce E. "Second-Order Voltage-Mode Universal Filters using Two DVCCs, Two Grounded Capacitors and Four Resistors". *Journal of Circuits, Systems and Computers*, 25(12), 1650154, 2016.