

A generalized classical method analysis of transient regimes in nonlinear electrical circuits by using differential taylor transform

Diferansiyel taylor dönüşümü kullanılarak doğrusal olmayan elektrik devrelerinde geçici rejimlerin geliştirilmiş klasik yöntem analizi

Teymuraz ABBASOV¹ , Teoman KARADAĞ¹ , Cemal KELEŞ^{1*} 

¹Department of Electrical and Electronics Engineering, Engineering Faculty, Inonu University, Malatya, Türkiye.
teymuraz.abbasov@inonu.edu.tr, teoman.karadag@inonu.edu.tr, cemal.keles@inonu.edu.tr

Received/Geliş Tarihi: 25.01.2023
Accepted/Kabul Tarihi: 23.01.2024

Revision/Düzeltilme Tarihi: 16.01.2024

doi: 10.5505/pajes.2024.69749
Research Article/Araştırma Makalesi

Abstract

In this study, we consider the Generalized Classical (GC) method based on the differential Taylor (DT) transform method for the analysis of transient regimes in simple electrical circuits. The approximate solution of nonlinear differential equations of electrical circuits with variable coefficients is found by using the GC method. It is shown that, if the solution is decomposed as steady-state and the temporary components, the use of the GC method can become more advantageous, and the transient differential equation of the circuits can be analyzed without a fully solving process. The efficiency of the considered method is illustrated by compared with the results obtained from similar problems in the literature. The results reveal that the proposed method is very effective and simple and can be applied to the analysis of both linear and nonlinear problems in physical systems. The short history and real status of the DT transform method are mentioned briefly.

Keywords: Differential Taylor transform, Differential spectrums, Generalized classical method, Electrical circuit, Transient regimes, Differential equations.

Öz

Bu çalışmada, basit elektrik devrelerinde geçici rejimlerin analizi için diferansiyel Taylor (DT) dönüşümü yöntemini temel alan geliştirilmiş Klasik (GK) yöntemini ele alıyoruz. Değişken katsayılı elektrik devrelerinin doğrusal olmayan diferansiyel denklemlerinin yaklaşık çözümü GK yöntemi kullanılarak bulunur. Çözümün kararlı durum ve geçici bileşenler olarak ayrıştırılması durumunda GK yönteminin kullanımının daha avantajlı hale gelebileceği ve devrelerin geçici diferansiyel denkleminin tam bir çözüme işlemi olmadan analiz edilebileceği gösterilmiştir. Ele alınan yöntemin etkinliği literatürdeki benzer problemlerden elde edilen sonuçlarla karşılaştırılarak gösterilmiştir. Sonuçlar, önerilen yöntemin çok etkili ve basit olduğunu ve fiziksel sistemlerdeki hem doğrusal hem de doğrusal olmayan problemlerin analizine uygulanabileceğini ortaya koymaktadır. DT dönüşüm yönteminin kısa tarihçesi ve gerçek durumundan kısaca bahsedilmiştir.

Anahtar kelimeler: Diferansiyel Taylor dönüşümü, Diferansiyel spektrumlar, Geliştirilmiş klasik yöntem, Elektrik devresi, Geçici rejimler, Diferansiyel denklemler.

1 Introduction

Electrical circuits generally consist of resistors, inductive windings, capacitors, semiconductor elements, devices and systems that convert different energies into electrical energy. The energy status of these systems is determined by the steady-state and transient regimes that occur in the circuits. The analysis of steady-state and transient regimes in electrical circuits is made according to Kirchhoff's laws and relations expressing the characteristics of the elements in the circuit. In this case, the state equations of electrical circuits are expressed by ordinary, partial differential or integro-differential equations [1]. Moreover, structurally similar equations take place in many different physical and technological systems (mechanical, heat and mass transfer, hydraulic, automation, etc.) [2]. Even if the characteristics of the elements of the electrical circuits are linear, the analytical solutions of these equations and therefore the analysis of transients in the circuit become difficult. In case the characteristics of electrical circuit elements are nonlinear, the examination of transient processes is more difficult and mainly carried out using numerical models [3]. Although numerical methods are advantageous for a particular case of transients in electrical circuits, they are not an effective approach for the general analysis of these circuits.

Because the results obtained by numerical methods are insufficient to explain some local events that are specific to transients in electrical circuits. Accordingly, it is very important to obtain analytical or approximate analytical solutions of linear, nonlinear differential or integro-differential equations of the circuit. In general, different approximate methods are used in the investigation of transients in nonlinear electric circuits [3]. These methods, which are effective in special cases, are not that advantageous in the analysis of nonlinear circuits in general. To simplify this process, transformation methods are widely used in the analysis of electrical circuits and automation problems in many areas [4]. Transformation methods such as Laplace, Fourier, Carson are used as basic instruments in the analysis of transients in physical processes whose energy states are expressed by linear differential equations [5],[6]. However, many difficulties are encountered in the application of these methods in the analysis of transients in nonlinear systems or circuits. Because when these integral transformation methods are applied to nonlinear systems, some mathematical operations are expressed very complex. For this reason, the search for new methods in the analysis of nonlinear systems is still up-to-date. One of these methods is the Differential Taylor (DT) transformation method [7]-[19], which has been proposed by G.E. Pukhov in recent years and

*Corresponding author/Yazışılan Yazar

given its basic concepts and application examples in many fields. This method, which allows obtaining both numerical and approximate analytical solutions of linear, nonlinear equations, ordinary differential equations (ODE), partial differential equations (PDE), and many physical models, has been used by many studies to solve various problems and is still widely used [20]-[58]. However, the pioneering role of G.E. Pukhov in all these studies presented in the literature has not been adequately evaluated. The studies of this scientist, who explained the basics of the DT transformation method with all its aspects and applications in five books published in 1970, were ignored. This method, which allows to obtain solutions of differential equations and functions with Taylor and Maclaurin series in general, has wider possibilities. Because functions (differential spectra) obtained by differential transform can be expressed not only with Taylor series, but also with any other function (exponent, rational fraction, Fourier series, etc.) depending on the physical properties of the system under consideration. This approach, which allows the examination of transient regimes in both linear and nonlinear systems using the DT transform, was defined by Pukhov as the Generalized Classical (GC) method [11],[13],[19].

In this study, current and voltage changes in transient regime in RC circuit with time varying $R(t)$ resistance were investigated by GC method. The change of the transient discharge current of the capacitor C under the effect of time varying $R(t)$ resistance in the electrical circuit, the solution of the nonlinear differential equation is obtained by using the DT transform. In the other approach, in the RC circuit, the variation of the discharge voltage of the capacitor over time was examined by defining the voltage-current characteristic over the nonlinear resistor in the form of a second-order polynomial. The results are discussed graphically. It was emphasized that the GC method, which was created on the basis of the DT transform method, is an advantageous instrument in the analysis of transients in linear and nonlinear physical systems and models. Brief history and status of the development of the differential Taylor transform method are also mentioned.

2 A short history and status of differential Taylor (DT) transform

Analytical solutions of differential equations used in the analysis of steady-state or transient events occurring in different fields of science are difficult or impossible in many cases. For this reason, various numerical methods have been developed to solve these problems. The development of modern computer systems and programs provides the opportunity to obtain numerical solutions of these equations. However, there is a need to obtain at least approximate analytical solutions of these equations. Because, in order to evaluate the effect of the changes in the different parameters of the physical processes expressed by these differential equations on the operating performance of this system, it is necessary to determine the relations between these parameters, even if they are approximate. In many cases, different transform techniques are used to solve these differential equations. These transform methods (Laplace, Fourier, Carson, Melville, etc.) in many cases greatly facilitate the process of obtaining analytical or approximate analytical solutions of either ODE or PDEs [4],[6],[59]. However, these methods, which are called integral transformation methods, are essentially more effective in solving constant coefficient and linear differential equations. These methods are often

insufficient for the solutions of variable coefficient and nonlinear integro-differential equations. It is also difficult to obtain the transfer functions of control systems expressed with such differential equations. This can prevent the automatic control and design of these systems [60]. Therefore, the development of new and more general transform techniques to solve similar problems remains a current issue. In this respect, it may be more advantageous to use differential transforms, which are performed with simpler operations, instead of integral transforms, which are often difficult to calculate. The concept of differential transform in mathematics is based on a very old history [61],[62]. However, the differential Taylor and non-Taylor transform method, which has been widely used in the solutions of integro-differential equations in recent years, is a relatively new transform method that started to develop in the 1960s. The Ukrainian scientist G.E. Pukhov (1916-1998) created the differential Taylor (DT) transform method for the first time and applied it to the solutions of various ODEs and PDEs, and to the examination of physical models in different fields of science, by giving all the basic concepts and rules of this method [7]-[19]. The most important advantage of the DT transform method is that both approximate analytical solutions of differential equations in the form of finite or infinite series and numerical solutions in the form of differential spectra can be obtained. Moreover, the solutions obtained in the DT transform method can be both Taylor and non-Taylor series (polynomial, rational fraction, exponent, functions with different structures, etc.). On the other hand, the DT transform method can be easily used together with many approximate methods (Poincare, Fourier, moment, finite differences, etc.) used in general mathematics. In addition, in DT transform applications, mathematical operations on linear and nonlinear coefficients of functions and differential equations are transformed into simple algebraic operations, including convolution. All these advantages show that the DT transform method has wide possibilities for modeling different physical processes. For this reason, the applications of the DT transform method, which was applied and developed by G.E. Pukhov, have been the main subject of the studies of many researchers in recent years and these application areas are still being developed [63]-[66]. In this period, the concepts and rules required for the creation of differential transforms of many functions, expressions, equations and obtaining their solutions were given by G.E. Pukhov. Examples of the application of these rules to electrical and electronic, heat-mass transfer, mechanical and other engineering problems are given in the author's books [14]-[19]. Since the 1990s, the DT transform method has been applied to the solutions of different differential equations by many scientists and is still being applied [20]-[66]. However, as a serious mistake in all these studies, it was stated that the first person to apply the DT transform was the Chinese writer Zhou. The reason for this is that this author, who has no other study on DT transform in the literature, has a book or dissertation published in Chinese in 1986 [67] and some Chinese scientists [21]-[23] have cited this publication. In the following period, other researchers' reference to these studies without extensive research caused this mistake to be carried to the international dimension. Although some studies [24]-[26],[32],[58] warned about this situation in the last period, the same approach still continues. Moreover, this serious mistake is found in the few books published on the application of the DT transform [63]-[66]. The main reason why G.E. Pukhov's studies on DT transform are not visible to world scientists may be that these studies are in

Russian. However, there are also a few extensive studies by G.E. Pukhov in English in the 1980s [10],[12]. In addition, the contents of the books [14]-[16],[19] containing the basics of DT transform are also given in English. Considering the concepts and symbols used in the main references to Zhou's Chinese book or dissertation [67], this source [67] appears to be a translation of G.E. Pukhov's books of the same name [14],[16]. For this reason, researchers working on DT transform applications should definitely consider this issue in their publications and examine the G.E. Pukhov's studies. Because in all the studies presented in the literature, almost all of the concepts, definitions and transform tables of DT transform are included in these books [14]-[19].

In this study, current and voltage changes in transient regime in nonlinear electrical circuits were investigated with the application of the GC method, which was created on the basis of the DT transform method. In order to shed light on the researchers working on DT transform, the definitions and formulas used in this study are given in the original form created by G.E. Pukhov.

3 Fundamentals of Differential Taylor (DT) transform

DT transform is an approximate method and is used for the analysis or solution of integro-differential equations or functions according to their differential spectra. The original function determined by the inverse function can generally be expressed as a Taylor series or any rational non-Taylor series function form. The most important advantage of the DT transform method is that it is simple and useful, and it provides the opportunity to obtain both numerical and analytical solutions of differential equations.

First of all, as in all transform techniques, in this study, the definition of original and inverse functions will be done as follows.

The original function is the continuous function $x(t)$, which depends on the real parameter t , and the inverse function is the transform functions $X(k)$ depending on the real integer argument $k = 0, 1, 2, \dots, \infty$.

In this case, according to G.E. Pukhov's definition [15], the DT transform of the function $x(t)$ or the differential spectrum at $t = t_v$ would be as follows:

$$X_v(k) = T\{x(t)\} = \frac{H^k}{k!} \left[\frac{d^k x(t)}{dt^k} \right]_{t=t_v} \quad (1)$$

Here, H is the scale constant of the same size as the t argument. If $t_v = 0$, then the series expansion of $x(t)$ would be the Maclaurin series and the differential spectra would be simpler,

$$X(k) = T\{x(t)\} = \frac{H^k}{k!} \left[\frac{d^k x(t)}{dt^k} \right]_{t=0} \quad (2)$$

Thus, according to Equation (1) or Equation (2), differential spectra $X(0), X(1), \dots$ can be easily calculated, with $k = 0, 1, 2, \dots, \infty$. According to these differential spectra, the original function $x(t)$ is obtained from the following inverse formula:

$$x(t) = T^{-1}\{X_v(k)\} = \sum_{k=0}^{\infty} \left(\frac{t - t_v}{H} \right)^k X(k) \quad (3)$$

As can be seen, the $x(t)$ function obtained from the inverse transform is a Taylor function expanded around the $t = t_v$ point. Within the radius of convergence, the function $x(t)$ is always analytical. In the DT transform, the radius of convergence ρ_c can be easily evaluated,

$$\rho_c = H \lim_{k \rightarrow \infty} \left| \frac{X(k)}{X(k+1)} \right| \quad (4)$$

In general, the DT transform has many similar properties that are characteristic of all integral transforms. However, it is very important to consider the following main features in DT transform applications, whether in the solution of differential equations or in the examination of physical models [14]-[19]. Although c is a constant, the following equations are valid for any two analytic functions $x(t)$ and $y(t)$;

$$T\{x(t) \pm y(t)\} = X(k) \pm Y(k) \quad (5)$$

$$T\{cx(t)\} = cX(k) \quad (6)$$

$$T\left\{ \frac{dx(t)}{dt} \right\} = X(k+1) \quad (7)$$

$$T\{x(t)y(t)\} = \sum_{l=0}^k \binom{k}{l} X(l)Y(k-l) \quad (8)$$

Here $\binom{k}{l} = \frac{k!}{l!(k-l)!}$ is the binomial coefficients.

The similarities and differences between Laplace and Fourier integral transforms and DT transform are given (see Table 1). However, unlike integral transforms, the transforms of many functions, especially the convolution theorem, are determined by simple algebraic expressions in the DT transform. This result reveals that the DT transform is more advantageous than integral transforms in solving nonlinear equations and modeling systems with varying parameters.

Table 1. Integral transforms and DT transform properties.

Operations	Laplace	Fourier	DT
$\{x(t)\}$	$X(s) = \int_0^{\infty} x(t)e^{-st} dt$	$X(j\omega) = \frac{1}{2\pi} \int_{-\infty}^{\infty} x(t)e^{-j\omega t} dt$	$X(k) = \left[\frac{\partial^k x(t)}{\partial t^k} \right]_{t=0}$
$\left\{ \frac{dx(t)}{dt} \right\}$	$sX(s) - X(0)$	$j\omega X(j\omega)$	$X(k+1)$
$\{x(t)y(t)\}$	$\frac{1}{j2\pi} \int_{s-j\omega}^{s+j\omega} X(\tau)Y(t-\tau) dt$	$\frac{1}{2\pi} \int_{-\infty}^{\infty} X(j\Omega)Y(j\omega - j\Omega) d\Omega$	$\sum_{l=0}^k \binom{k}{l} X(l)Y(k-l)$

The fundamental principle and scientific basis of the application of the DT transform to the solutions of many electrotechnical problems, such as the investigation of linear and nonlinear electric circuits and systems with distributed parameters, are studied in detail in Pukhov's books [14-16]. The DT transforms of some important functions used in these applications are given (see Table 2). DT transforms of more complex functions and equations are explained in Pukhov's books [14]-[19] with examples and tables.

By using Table 2, DT models of many linear, nonlinear, and variable coefficient differential equations can be created and

simpler solutions are obtained. The most important point here is to obtain both analytical (Taylor and non-Taylor series) and numerical solutions in spectral form from DT models. For example, a first-order linear differential equation in general form is given as follows:

$$\frac{dx(t)}{dt} + a(t)x(t) = f(t) \quad (9)$$

Table 2. DT transformations of some functions and mathematical operations [14-19].

Number	Original function or expressions	Differential spectrum
1	$x(t)$	$X(k) = \frac{H^k}{c!} \left[\frac{d^k x(t)}{dt^k} \right]_{t=0}$
2	1	$\delta(k) = \begin{cases} 1, k = 0 \\ 0, k \neq 0 \end{cases}$
3	t	$T(k) = H\delta(k-1) = \begin{cases} H, k = 1 \\ 0, k \neq 1 \end{cases}$
4	$t^m, (m \in \mathbb{N})$	$T^m(k) = H^m \delta(k-m) = \begin{cases} H^m, k = m \\ 0, k \neq m \end{cases}$
5	$(1+t)^m$	$\begin{cases} H^k \frac{m!}{k!(m-k)!}, & \text{if } m \in \mathbb{N} \\ H^k \frac{m(m-1)\dots(m-k+1)}{k!}, & \text{if } m \text{ is a random number} \end{cases}$
6	e^{ct}	$E_c(k) = \frac{(cH)^k}{k!}$
7	$\sin \omega t$	$S_\omega(k) = \frac{(\omega H)^k}{k!} \sin \frac{\pi k}{2}$
8	$\cos \omega t$	$C_\omega(k) = \frac{(\omega H)^k}{k!} \cos \frac{\pi k}{2}$
9	$shct$	$Sh_\omega(k) = \frac{(cH)^k}{k!} \sin^2 \frac{\pi k}{2}$
10	$chct$	$Ch_\omega(k) = \frac{(cH)^k}{k!} \cos^2 \frac{\pi k}{2}$
11	$\ln(1+ct)$	$\ln(k) = \frac{(cH)^k}{k!} [\delta(k) - \cos \pi k]$
12	$x(0) = \text{constant}$	$X(0)\delta(k)$
13	$cx(t)$	$cX(k)$
14	$x(ct)$	$c^k X(k)$
15	$x(t)y(t)$	$\sum_{l=0}^k X(k-l)Y(l)$
16	$x^2(t)$	$\sum_{l=0}^k X(k-l)X(l)$
17	$x^m(t)$	$\sum_{l=0}^k X(k-l)X^{m-1}(l)$
18	$t^m x(t)$	$H^m X(k-m)$
19	$\frac{dx(t)}{dt}$	$\frac{k+1}{H} X(k+1)$
20	$\frac{dx^m(t)}{dt^m}$	$\frac{(k+m)!}{k! H^m} X(k+m)$
21	$\int x(t)dt$	$H \frac{X(k-1)}{k} + c\delta(k), \quad c \text{ is a random integral constant}$

Considering Table 2, the DT model of this differential equation becomes as follows:

$$\frac{k+1}{H}X(k+1) + \sum_{l=0}^k A(k-l)X(l) = F(k) \quad (10)$$

$X(k)$ differential spectra can be easily calculated from Equation (10) when given as $k = 0, 1, 2, \dots, \infty$. According to the calculated $X(k)$ spectra, the original function $x(t)$ from Equation (3) is obtained in Taylor series form or as an exact function. This approach was described by G.E. Pukhov as the "DT direct method" or the DT-1 model [14-19]. Although it seems simple in theory, the DT-1 model is not advantageous in many practical applications. Because $X(k)$ differential spectra have different dimensions. In addition, since the convergence of the Taylor series in Equation (3) is not fast enough in many cases, the calculation process becomes difficult and the resulting calculation errors can reach undesired levels. In order to eliminate these difficulties, G.E. Pukhov suggested the more efficient non-Taylor method by combining the $X(k)$ differential spectra obtained by the DT method with different approximation methods such as Picard, Newton-Kantorovich, Poincare, Bubnov-Galerkin, small squares approximation, finite elements method, etc. [14]-[19]. Pukhov had been shown that the GC approach is more effective in addition to the DT-1 method in the solution of electrotechnical problems [12]. Many properties specific to processes in electrical circuits and systems (e.g. commutation laws, stability, limited values of parameters such as current-voltage-magnetic flux in the circuit, etc.) facilitate the creation of a DT model of these problems. Accordingly, in the next section, the creation of the DT model of some electrotechnical problems and the examination of simple transients with the DT-based GC method are discussed.

4 Differential transform and generalized classical method

Let's assume that the state equation of the physical model or process to be investigated is given as the following differential equation,

$$\frac{dx(t)}{dt} = f[t, x(t)], \quad x(0) = x_0 \quad (11)$$

The solution of this equation is generally obtained with the following integral equation,

$$x(t) = x(0) + \int_0^t f[\tau, x(\tau)]d\tau \quad (12)$$

Here $x(t)$ and $f[\tau, x(t)]$ are the basis functions and $x(0)$ is the initial value of the function $x(t)$ for $t = 0$.

If Equation (11) or Equation (12) has only one solution, it can be assumed that the solution consists of two components:

$$x(t) = x_S(t) + x_T(t) \quad (13)$$

Here, $x_S(t)$ is steady-state component and $x_T(t)$ is temporary component [12],[19]. In physical systems, the function of the system that stabilizes over time ($t \rightarrow \infty$) can be selected as a steady-state component. It is a unique function with a limited amplitude and independent of the initial moment ($t = 0$).

In general, the steady-state component can also be chosen as approximately equal to one particular solution of the given

equation. The analytic structure of the temporary component $x_T(t)$ should be chosen in such a way that the approximate function $x_T(t, c)$ representing this function is complete and damped. Here $c = c_0, c_1, \dots, c_n$ are undetermined coefficients and are determined according to the initial, boundary conditions or any other property of the system. The DT method can be used to determine these coefficients. For this purpose, differential Taylor spectra of Equation (13) are obtained.

$$X(k) = \frac{H^k}{k!} \left[\frac{d^k x(t)}{dt^k} \right]_{t=0} \quad (14)$$

$$X_S(k) = \frac{H^k}{k!} \left[\frac{d^k x_S(t)}{dt^k} \right]_{t=0} \quad (15)$$

$$X_T(k) = \frac{H^k}{k!} \left[\frac{d^k x_T(t)}{dt^k} \right]_{t=0} \quad (16)$$

If the DT spectra of the function $f[t, x(t)]$ are assumed to be $F(k)$, then the $X(k)$ spectra $[X(0), X(1), \dots, X(k)]$ can be easily determined from Equation (11) or Equation (12). Here, in accordance with the DT method, if it is desired to form the differential spectra of the functions according to the main differential equation of the physical process under investigation, then these spectra are determined from formulas or tables [14]-[19].

The structure of the temporary function (rational fraction, exponent, Fourier series, etc.) is selected according to the character of the problem and initial conditions,

$$x_T(t, c) = x_T[t, c_0\beta_0(t), c_1\beta_1(t), \dots, c_n\beta_n(t)] \quad (17)$$

Using Equations (14), (15), and (16), we obtain the spectrum equation of the given nonlinear problem,

$$X(k) = X_S(k) + X_T[T(k), c_0B_0(k), c_1B_1(k), \dots, c_nB_n(k)] \quad (18)$$

Here, $B_0(k), B_1(k), B_2(k), \dots, B_n(k)$ are differential spectra of selected $\beta_0(t), \beta_1(t), \beta_2(t), \dots, \beta_n(t)$ functions. The $T(k)$ spectrum is determined as follows.

$$T(k) = T\{t\} = \frac{H^k}{k!} \left[\frac{d^k t}{dt^k} \right]_{t=0} = H\delta(k-1) = (0, H, 0, \dots, 0) \quad (19)$$

The term $\delta(k)$ in this expression is defined as follows [13-18],

$$\delta(k) = \begin{cases} 1, & k = 0 \\ 0, & k \neq 0 \end{cases} \quad (20)$$

c_n coefficients are determined from Equation (18) according to the $X(k)$ spectra determined from the fundamental differential function or equation and the spectra of the steady-state component $X_S(k)$. Considering Equation (17), an approximate analytical solution of the problem given from Equation (13) is obtained according to certain c_n coefficients. As can be seen, while Equation (13) is being created, no constraint conditions other than the physical properties of the nonlinear system are required. In other words, the detailed procedure of the solutions of the differential equations expressing the transient events occurring in the nonlinear system may not be taken into account. Moreover, when the DT transform is applied, the procedure followed for examining transients in nonlinear systems can be similar to the procedure performed for

examining transient regimes in linear systems. For this reason, this method was named as GC method is tolerable both linear and nonlinear transient processes by G.E. Pukhov [12],[19]. When this method is applied, many transient events in electrical circuits and systems can be easily examined.

5 Basic concepts of investigation of electrical circuits and systems with DT transform

5.1 Creation of DT models of circuit elements and fundamental laws in electrical circuits

The laws of electrophysics constitute the theoretical basics of electrotechnical. These laws are Kirchhoff's laws, which determine the relationship between currents and voltages in the circuit, the state equations of electrical circuit elements, and Maxwell's equations. Usually these equations take the form of specific ODE and PDE. DT models of Ohm and Kirchhoff's laws and circuit elements such as resistors, diodes, inductive windings, capacitors, transformers are obtained as follows [14]-[16].

$$\sum_{m=1}^{\mu} I_m(k) = 0, \quad \sum_{m=1}^{\mu} U_m(k) = 0 \quad (21)$$

$$U_m(k) = RI(k) \quad (22)$$

Here $I(k) = T\{i(t)\}$ and $U(k) = T\{u(t)\}$ is the T model of current $i(t)$ and voltage $u(t)$, respectively.

As can be seen, while R is constant, Kirchhoff's first and second laws and Ohm's law provide their original form in the DT transform. Since electrical circuit elements (resistor, inductance, and capacitance) can be both linear and nonlinear, the voltage-current characteristics of these elements are expressed with differential or integral relations. Therefore, the expressions of these elements in the state equations of the electrical circuits should also be subjected to the DT transform. DT models of voltage-current characteristics over resistance, inductance and capacitance are shown (see Table 3).

For example, in the RLC circuit (see Figure 1), the state equation in transient (when the switch is turned on) is written as follows:

$$\frac{d^2 Q(t)}{dt^2} + \frac{R}{L} \frac{dQ(t)}{dt} + \frac{1}{LC} Q(t) = \frac{E}{L} \quad (23)$$

Here $Q(t)$ is the electric charge. By using Table 3, the DT model of this differential equation becomes as follows:

$$\frac{(k+1)(k+2)}{H^2} Q(k+2) + \frac{R(k+1)}{L} \frac{H}{E} Q(k+1) + \frac{1}{LC} Q(k) = \frac{E}{L} \delta(k) \quad (24)$$

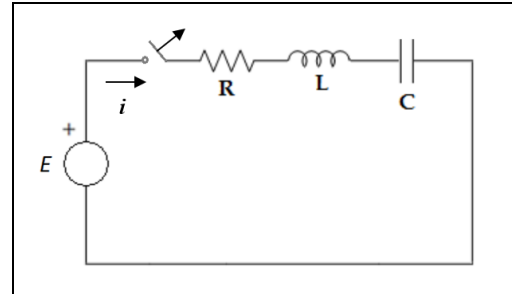

Figure 1. Transients in a simple RLC electrical circuit: R, L, C are constant.

According to the calculated $Q(k)$ spectra ($k = 0,1,2, \dots$) from Equation (24), $Q(t)$ original function and then $i(t)$ current change can be determined in accordance with Equation (3). However, the RLC circuit elements (see Figure 1) can be both constant and variable. Although Equation (23) is relatively easy to solve if the RLC elements are constant. If any of these elements are variable over time, the DT model becomes difficult and the convergence rate of the Taylor series in Equation (3) decreases, and the margin of error of the calculations increases. However, if the variation characteristics (such as linear, exponent, increasing or decreasing function, etc.) of the electrical circuit parameters are known beforehand, the solution of the problem can be facilitated. Because we can define the variation of current or voltage in the circuit as a series, polynomial or any other function with uncertain coefficients that can satisfy the boundary conditions in this circuit. Then, using the spectra obtained from the DT model in Equation (24), the uncertain coefficients of these functions can be easily determined [12],[19]. In the following section, the analysis of the current and voltage changes in the discharge event of the capacitor C over the nonlinear $R(t)$ resistor in the simplified RC electrical circuit with the GC method is discussed.

5.2 Investigation of discharge events in nonlinear RC electric circuits by GC method

First of all, let's create the general model of transients in simple nonlinear RC electric circuits using the DT transform on the basis of the GC method. As an example, the discharge event of the capacitor in the RC circuit containing the non-linear resistor $R(t)$ will be considered. In the circuit without current source (see Figure 2), the transient regime is determined as follows:

Table 3. Integral transforms and DT transform properties.

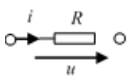
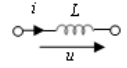
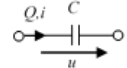
Circuit Element	Voltage-Current Relationship	DT Model
Resistor 	$U_R(t) = i_R(t)R$ $R = \text{constat}$ $U_R(t) = i_R(t)R(t)$ $R = \text{variation}$	$U(k) = RI(k)$ $U(k) = R(k)I(k) = \sum_{l=0}^k R(k-l)I(l)$
Inductance 	$U_L(t) = L \frac{di_L(t)}{dt}$	$U(k) = \frac{L}{H} (k+1)I(k+1)$
Capacitance 	$i_C(t) = C \frac{dU_C(t)}{dt}$	$I(k) = \frac{C}{H} (k+1)U(k+1)$

$$i(t)R(t) + \frac{1}{C} \int_0^t i(t)dt = U_0 \quad (25)$$

Here U_0 is the voltage of the capacitance at time $t = 0$. The $R(t)$ resistor in the circuit changes over time as a result of the heating caused by the effect of the discharge current $i(t)$. In this case, the change of current $i(t)$ in the circuit can be determined as follows [68].

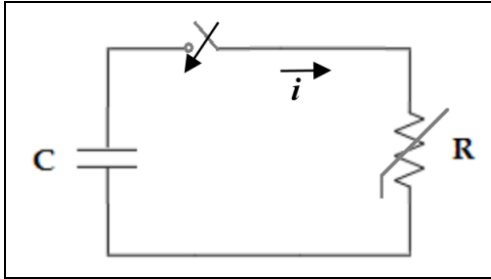

Figure 2. Transients in a simple nonlinear RC circuit:
 $u(0) = U_0$.

If it is assumed that the heat transfer between the resistor and the external environment is negligible during the transient regime, the amount of heat generated on the resistor is completely spent on heating the resistor. In this case, it can be assumed that the dependence of the resistance $R(t)$ on the temperature θ is linear.

$$R(t) = R_0(1 + \alpha[\theta(t) - \theta_0]) = R_0 + \frac{\alpha R_0}{C_R} \int_0^t i^2(t)R(t)dt \quad (26)$$

Here, α is the temperature coefficient of the resistor, R_0 is the initial value of the resistor, C_R is the heat susceptibility of the resistor.

By taking the derivatives of Equations (25) and (26), the state equation for the discharge event of the capacitor is obtained,

$$\frac{d[i(t)R(t)]}{dt} + \frac{i(t)}{C} = 0 \quad (27)$$

$$\frac{dR(t)}{dt} = \frac{\alpha R_0}{C_R} R(t)i^2(t), \quad R(0) = R_0, \quad i(0) = I_0 \quad (28)$$

Here $I_0 = U_0/R_0$ is the initial value of the current. Equation (27) and (28) are expressed as dimensionless as follows:

$$\frac{d(xy)}{d\theta} + y = 0 \quad (29)$$

$$\frac{dx}{d\theta} = 2\epsilon xy^2 \quad x(0) = 1, \quad y(0) = 1 \quad (30)$$

Here,

$$x(t) = \frac{R(t)}{R_0}, \quad y(t) = \frac{i(t)}{I_0} = \frac{R_0}{U_0} i(t), \quad \theta = \frac{t}{CR_0} \quad (31)$$

$$\epsilon = \frac{\alpha CU_0^2}{2C_R} = \frac{\alpha Q_{max}}{C_R} = \alpha \Delta T_{max} = \frac{R_\infty - R_0}{R_0}$$

$Q_{max} = 0,5CU_0^2$ in Equation (31) is the amount of heat received by the resistor during the whole discharge period. During this time the resistor value increases from R_0 to R_∞ .

If $\epsilon = 0$ in Equation (31), R becomes constant, that is, the transient regime of the linear RC circuit is examined. For easier understanding of the solution of the problem, the parameter q , which is always less than 1, can be used instead of ϵ in Equation (31),

$$q = \frac{\epsilon}{1 + \epsilon} = \frac{R_\infty - R_0}{R_\infty} = 1 - \frac{R_0}{R_\infty} < 1 \quad (32)$$

In this case, the dimensionless time calculated according to the resistor R_∞ can be expressed as follows:

$$\tau = (1 - q)\theta = \frac{\theta}{1 + \epsilon} = \frac{t}{CR_\infty} \quad (33)$$

Considering these definitions, the final form of Equation (29) and (30) can be written as follows [68].

$$\frac{d(xy)}{d\tau} + \frac{1}{1 - q}y = 0 \quad (34)$$

$$\frac{dx}{d\tau} = \frac{2q}{(1 - q)^2}xy^2, \quad x(0) = 1, \quad y(0) = 1 \quad (35)$$

Equation (29) and (30) or Equation (34) and (35), which are nonlinear differential equations, allow the examination of the transient regime in a RC circuit containing nonlinear $R(t)$. The analytical solution of this equation is not easy and requires special approaches [68]. However, this transient regime can be easily studied using the GC method [12],[32]. For the solution of these equations with the DT method, the DT spectrum model of Equations (34) and (35) is as follows [11]-[18]:

$$\frac{1}{H} \sum_{l=0}^k Y(k-l)(l+1)X(l+1) + \frac{1}{H} \sum_{l=0}^k X(k-l)(l+1)Y(l+1) + \frac{1}{1-q}Y(k) = 0 \quad (36)$$

$$\frac{k+1}{H}X(k+1) = \frac{2q}{(1-q)^2} \sum_{l=0}^k X(k-l) \sum_{s=0}^l Y(l-s)Y(s), \quad X(0) = 1, Y(0) = 1 \quad (37)$$

The solutions of Equations (34) and (35), which express the state equation of the RC circuit in accordance with the GC method created on the basis of DT, can be written as follows:

$$y(\tau) = y_s(\tau) + y_r(\tau) \quad (38)$$

$$x(\tau) = x_s(\tau) + x_r(\tau) \quad (39)$$

According to the characteristics of the problem under investigation, the following boundary conditions must be met for the solutions given in Equations (38) and (39),

$$(\tau = 0) = 1, x(\tau \rightarrow \infty) = \frac{R_\infty}{R_0} = \frac{1}{1 - q} \quad (40)$$

$$y(\tau = 0) = 1, y(\tau \rightarrow \infty) = 0 \quad (41)$$

Hence, the steady-state components for Equations (38) and (39) are

$$x_s(\tau) = \frac{R_\infty}{R_0} \quad (42)$$

$$y_s(\tau) = 0 \quad (43)$$

The following criteria should be considered in determining the functional relations of the temporary components $x_T(\tau)$, and $y_T(\tau)$: If the time variation of the resistor $R(t)$ in the circuit occurs approximately exponentially, the time variation of the current and voltage in the nonlinear RC circuit can also be chosen as an exponential function. Accordingly, the functional structure of temporary components can be as follows:

$$x_T(\tau) = C_0 + C_1 e^{-s\tau} \quad (44)$$

$$y_T(\tau) = \frac{1 + a_1\tau}{1 + b_1\tau + b_2\tau^2} \quad (45)$$

Here, C_0, C_1, a_1, b_1, b_2 and $s > 0$ are undetermined coefficients. The DT spectra of Equations (44) and (45) are obtained for $H = 1$ as follows:

$$X(k) = C_0\delta(k) + C_1 \frac{(-s)^k}{k!} \quad (46)$$

$$Y(k) + b_1 Y(k-1) + b_2 Y(k-2) = \delta(k) + a_1 \delta(k-1) \quad (47)$$

When Equation (37) is taken into account, the spectra of Equation (46) at $k = 0, 1, 2, \dots$ values are as follows:

$$C_0 = \frac{R_\infty}{R_0}, \quad C_0 + C_1 = 1, \quad X(1) = -sC_1 \quad (48)$$

The coefficients are determined from the $X(k)$ spectra calculated from here and Equation (37):

$$C_0 = \frac{R_\infty}{R_0} = \frac{1}{1-q}, \quad C_1 = 1 - \frac{R_\infty}{R_0} = -\frac{1}{1-q}, \quad (49)$$

$$s = \frac{-X(1)}{C_1} = \frac{2}{1-q}$$

Considering these values, the variation of the resistor with time is obtained from Equation (39) as dimensionless:

$$x(\tau) = \frac{1}{1-q} - \frac{1}{1-q} \exp\left(-\frac{2}{1-q}\tau\right) = \frac{1}{1-q} \left[1 - q \exp\left(-\frac{2}{1-q}\tau\right)\right] \quad (50)$$

As can be seen from Equation (50), the boundary conditions $x(\tau = 0) = 1$, and $x(\tau \rightarrow \infty) = R_\infty/R_0$ are provided.

In order to examine the change of current in the circuit, $Y(k)$ spectra are determined from Equation (36):

$$Y(1) = -\frac{(1+q)H}{(1+q)^2}$$

$$Y(2) = \frac{H^2(1+8q+q^2)}{2!(1-q)^4} \quad (51)$$

$$Y(3) = -\frac{H^3(1+32q+64q^2+20q^3+3q^4)}{3!(1-q)^6}$$

By considering these spectra in Equation (47), the coefficients a_1, b_1 and b_2 are easily determined as follows:

$$a_1 = \frac{3q^4 + 8q^3 + 16q^2 - 4q + 1}{3(1-q)^2(q^2 + 4q - 1)}$$

$$b_1 = \frac{3q^4 + 11q^3 + 31q^2 + 5q - 2}{3(1-q)^2(q^2 + 4q - 1)} \quad (52)$$

$$b_2 = \frac{6q^5 + 19q^4 + 24q^3 - 18q^2 + 18q - 1}{6(1-q)^4(q^2 + 4q - 1)}$$

Thus, the temporary component function expressed by Equation (45) is determined. This expression corresponds to the dimensionless variation of the transient discharge current in the nonlinear RC circuit according to Equation (38) together with Equation (43). In the literature [68], the result was calculated with $O(q^2)$ error in the Lambert W-function method. According to these results, the changes of current and resistor over time in the RC charging circuit were obtained approximately as follows [68]:

$$\frac{i(t)}{I_0} = e^{-\tau} [1 - 1.5q(1 - e^{-\tau})] \quad (53)$$

$$\frac{R(t)}{R_0} = 1 + q(1 - e^{-2\tau}) \quad (54)$$

When such an approach is applied in Equation (52), the coefficients in GC method are simplified:

$$a_1 = \frac{-1}{3(1-q)^2}, \quad b_1 = \frac{2+3q}{3(1-q)^2}, \quad b_2 = \frac{1+22q}{6(1-q)^4} \quad (55)$$

In this case, the variation of the transient current with time in the linear RC circuit is obtained from Equation (38) as follows:

$$y(\tau) = \frac{6(1-q)^4 - 2(1-q)^2\tau}{6(1-q)^4 + 2(2+3q)(1-q)^2\tau + (1+22q)\tau^2} \quad (56)$$

In many cases, the variation of the resistor with time in the nonlinear RC circuit (see Figure 2) is not given directly, for example, by the nonlinear voltage-current characteristic. These voltage-current characteristics can be given with different functional relationships (eg exponent, harmonic sine or cosine, series or polynomials etc.). In this case, current or voltage changes in the circuit can be easily solved by GC method using DT transform. For example, let's assume that the voltage-current characteristic of the nonlinear resistor in the above RC circuit is given as follows:

$$i(t) = B_1 u(t) + B_2 u^2(t), \quad u(0) = U_0 \quad (57)$$

In this case, the variation of the voltage $u(t)$ with time is as follows with the GC method. The variation of the voltage $u(t)$ in the circuit with time is determined according to the differential equation of the circuit written in dimensionless form [18]:

$$\frac{dz(\tau)}{d\tau} + z(\tau) + \mu z^2(\tau), \quad z(0) = 1 \quad (58)$$

Here, $z = u(t)/U_0, \tau = (B_1/B_2)t, \mu = (B_2/B_1)U_0$

The variation of the voltage with time in the transients in the circuit is written dimensionless as follows:

$$z(\tau) = z_s(\tau) + z_T(\tau) \quad (59)$$

According to the flow character of the transient, $z(\tau \rightarrow \infty)$ must be zero. In this case, $z(0) = 1$, so $z_s(\tau) = 0$. The temporary component $z_T(\tau)$ can be chosen as any function that satisfies

the above properties, for example as in Equation (45). For a different approach, the temporary component is considered as follows:

$$z_T(\tau) = c_3 e^{-\tau} + c_4 \tau e^{-\tau} \quad (60)$$

Here c_3 and c_4 are undetermined coefficients. Therefore, the solution of Equation (58) is as follows:

$$z(\tau) = c_3 e^{-\tau} + c_4 \tau e^{-\tau} \quad (61)$$

T models of these equations are obtained as follows [18], $H = 1$

$$(k + 1)Z(k + 1) + Z(k) + \mu \sum_{l=0}^k Z(k - l)Z(l) = 0 \quad Z(0) = 1 \quad (62)$$

$$\sum_{l=0}^k \frac{(1)^{k-l}}{(k-l)!} Z(l) = c_3 \delta(k) + c_4 \delta(k - 1) \quad (63)$$

From here, for example, since $Z(0) = 1$, $Z(1) = -1,5$, and $Z(2) = 1,5$ for $\mu = 0,5$, $c_3 = 1$ is found as $c_4 = -0,5$. The final approximate solution of Equation (58) is as follows:

$$z(\tau) = e^{-\tau} - 0,5\tau e^{-\tau} \quad (64)$$

6 Results and discussion

As can be seen from the above analysis, it is possible to obtain approximate analytical and numerical solutions of the problem by examining the transient regimes in the RC circuit with nonlinear varying resistor using the DT method. This approach can also be used effectively in the analysis of state equations expressed in linear and nonlinear integro-differential equations in many physical models. The GC method based on DT transform has many advantages for investigating the state equations of transient events in electrical circuits and systems. Because by using the GC method, transients in both linear and nonlinear electric circuits can be obtained with an approach expressed by Equation (13) without detailed solutions of the differential state equations of these circuits. Especially in cases where the analytical solutions of transient equations, which are expressed with nonlinear and variable coefficient differential equations, are difficult or impossible in many cases. The GC method provides the opportunity to obtain analytical solutions of the problem, although it is always approximate. In this case, the steady-state $x_s(\tau)$, and temporary $x_T(\tau)$ functions of the electric circuit can be chosen as sufficiently convergent functions that satisfy the physical properties of the transients in this circuit.

The results of the variation of the discharge current of the capacitor in the nonlinear RC circuit with respect to time, calculated according to Equation (56), are given (see Figure 3). For comparison, the variation of the current in the constant resistive state is also shown as dashed lines on the graph. The variation of the normalized value of the resistor in the circuit with respect to dimensionless time is shown (see Figure 4).

The change of transient current in the nonlinear RC circuit is affected by the change of the resistive resistance from q parameter (see Figure 3). According to the results presented in the literature [68], this change can be approximately determined by Equation (53). Moreover, the time variation of the transient current changes faster initially, then decreases exponentially, compared to the case where R is constant.

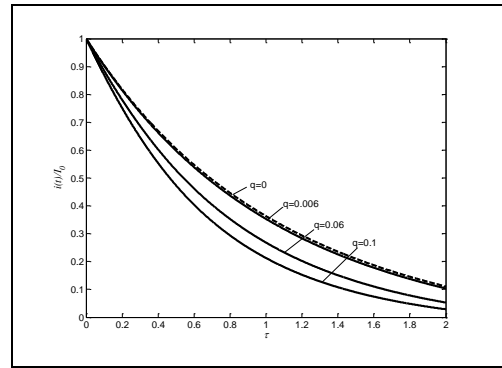

Figure 3. Variation of the discharge current in the capacitor with respect to dimensionless time with different q .

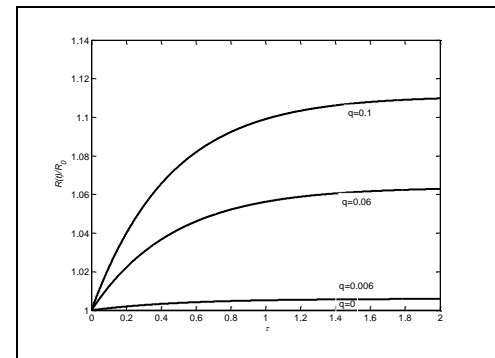

Figure 4. Variation of the resistor with respect to dimensionless time with different q .

The graphs of the approximate solution obtained from Equation (56) by GC method compared to the approximate solution presented in the literature [68] and given in Equation (53) are shown (see Figure 5).

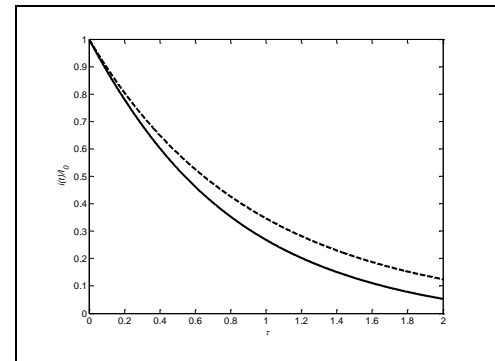

Figure 5. Comparison of the results obtained according to different approximate solutions of the variation of the discharge current in the capacitor with respect to dimensionless time: Equation (53) shown as dash line; Equation (56) shown as solid line, $q = 0.06$.

The transient current change in the nonlinear RC circuit is in principle correctly expressed by the results obtained from both solutions (see Figure 5). However, the approximate solution in Equation (56) expresses the dependence of the variation of the transient current on q more sensitively. In order to increase the convergence of the solution of the problem to the real solution, it is necessary to increase the number of components in the approximate solution. However, it is not mathematically easy to increase the number of components in the approximate solution (Equation (53)) obtained in the literature [68]. In

Equation (45) in the GC method, it is possible to increase the number of components and the DT spectra of these components sufficiently. On the other hand, we can mathematically choose the shape of these components to be similar to the components in Equation (53). The variation of the resistor $R(t)$ with time (see Figure 4) is given in Equations (50) and (54). Both approximate solutions obtained by the GC method (Equation (50)) and presented in the literature [68] (Equation (54)) show that the variation of this resistor changes by twice the time constant according to the transient current. However, as can be seen from equation (50), the variation of the resistor $R(t)$ with respect to q in the approximate formula obtained by the GC method is more sensitive than Equation (54). Therefore, these results show that the GC method has wider possibilities than the method presented in the literature [68] in the investigation of transients in nonlinear electrical circuits generally.

7 Conclusions

The following results are obtained from the analysis of the possibilities of using the GC method, which is formed on the basis of the DT transform, in the analysis of transients in nonlinear electrical circuits.

- i. DT transform method is a spectral model created on the basis of determination of differential spectra. This method was determined for the first time by the Ukrainian scientist GE Pukhov, and it has been applied in solving basic concepts and different mathematical problems, and in the creation of physical models,
- ii. DT transforms of linear or nonlinear ODEs or PDEs with varying coefficients are easier and more useful in practical applications than the integral transform methods commonly used in the literature, since they involve simple algebraic operations. The results obtained by this method can be both numerically in the form of spectra and analytically in the form of an approximate serial or functional relationship. Although the inverse transform of the original function according to the differential spectra is essentially in the form of Taylor series, the DT method is a more universal method that allows to determine the original function in the form of different functions as non-Taylor,
- iii. With the DT-based GC method, it is possible to consider the solution of transients occurring in any dynamic system expressed with nonlinear ODE or PDE as a function consisting of steady-state and temporary components. The steady-state component can be determined according to the stable condition in the system. The temporary component can be chosen as an approximate function that satisfies the initial or boundary conditions in the system or can satisfy any conditions. The uncertain coefficients contained in this function are determined using the differential spectra obtained from the differential transform of the fundamental differential equation of the system,
- iv. The basic criterion in the selection of the temporary component is that this function is an entire function that can satisfy the initial, boundary or any special conditions. Therefore, the functional structure of this component can be chosen as any function (Taylor or Maclaurin series, rational fraction, polynomial,

exponent, Fourier series, etc.) with uncertain coefficients. The basic principle here is that the selected functions can provide a fast convergence. The use of numerical methods, which are widely used in traditional mathematics, can accelerate these calculation processes in finding the uncertain coefficients,

- v. The DT-based GC method has extensive possibilities to examine transients in both linear and nonlinear electrical circuits with the same approach or a similar procedure. If there is a stable steady-state regime in nonlinear electric circuits and this solution is unique, we can obtain the transient regimes in such electric circuits without solving the basic integro-differential state equation of the circuit using the GC method,
- vi. Analysis of the transients in a simple nonlinear RC circuit with DT transform showed that the results of the transient current or voltage changes in the circuit obtained by the GC method are more comprehensive than the solutions presented in the literature and determined by other approximate methods. Studies also show that the GC method can be used as an advantageous instrument for the analysis of transients in more complex electrical circuits and systems.

8 Author contributions

In this study, Teymuraz ABBASOV contributed to the supervision, conceptualization, data curation, methodology, literature review, evaluation of data and validation, Teoman KARADAĞ contributed to review and editing, Cemal KELEŞ contributed to data curation, the formal analysis, software, writing and editing. All authors have read and agreed to the published version of the manuscript.

9 Ethics committee approval and conflict of interest

"There is no need to obtain ethics committee approval for the article prepared".

"There is no conflict of interest with any person/institution in the prepared article".

10 References

- [1] Williams G. *Introduction to Electrical Circuit Theory*. Latest Ed. London, England, Red Globe Press, 1973.
- [2] Brawne TE. *Circuit Interruption. Theory and Techniques*. 1st ed. Pennsylvania, USA, CRC Press, 1984.
- [3] Goulart de Siqueira JC, Bonato BD. *Introduction to Transients in Electrical Circuits, Analytical and Digital Solution Using An Emtp-Based Software*. 1st ed. Basel, Switzerland, Springer Cham Press, 2021.
- [4] Poularikas AD. *Transforms and Applications Handbook*. 3rd ed. Boca Raton, Florida, USA, CRC Press Taylor & Francis Group, 2010.
- [5] Duffy DG. *Transform Methods for Solving Partial Differential Equations*. 2nd Ed. Boca Raton, Florida, USA, Chapman & Hall CRC Press, 2004.
- [6] Poularikas AD. *The Transforms and Applications Handbook*. 2nd ed. Boca Raton, Florida, USA, CRC Press, 2000.

- [7] Pukhov GE. *The Application of Taylor Transformations to Solving Differential Equations. Electronics and Modeling*. 1st Ed. Kyiv, Ukraine, Naukova Dumka Press, 1976.
- [8] Pukhov GE. *Calculation of Electric Chains By Means of Taylor Transformations. Electronics and Modeling*. 1st ed. Kyiv, Ukraine, Naukova Dumka Press, 1976.
- [9] Pukhov GE. *Taylor Transformations Related to The Laplace and Fourier Integral Transforms. Problems in Electronics and Computational Techniques*. 1st ed. Kyiv, Ukraine, Naukova Dumka Press, 1976.
- [10] Pukhov GE. "Expansion formulas for differential transforms". *Cybernetics and Systems Analysis*. 17, 460-464, 1981.
- [11] Pukhov GE. "Differential transforms and circuit theory". *Journal of Circuit Theory and Applications*, 10, 265-276. 1982.
- [12] Pukhov GE. "Examples on nonstationary process simulation by generalized classical method". *Electronical Modelling*, 12(5), 90-94, 1990.
- [13] Pukhov GE. "Calculation of transients in the nonlinear electrical circuits with pulse sources". *Electronical Modelling*, 13(4), 44-50, 1991.
- [14] Pukhov GE. *Taylor Transforms and Their Application in Electrotechnics and Electronics*. 1st ed. Kyiv, Ukraine, Naukova Dumka Press, 1978.
- [15] Pukhov GE. *Differential Transformations of Functions and Equations*. 1st ed. Kyiv, Ukraine, Naukova Dumka Press, 1980.
- [16] Pukhov GE. *Differential Analysis of Electrical Circuits*. 1st Ed. Kyiv, Ukraine, Naukova Dumka Press, 1982.
- [17] Pukhov GE. *Differential Transformation and Mathematical Modelling of Physical Processes*. 1st ed. Kyiv, Ukraine, Naukova Dumka Press, 1986.
- [18] Pukhov GE. *Approximation Methods of Mathematical Modelling Based on Differential T-Transformation*. 1st Ed. Kyiv, Ukraine, Naukova Dumka Press, 1988.
- [19] Pukhov GE. *Differential Spectra and Models*. 1st ed. Kyiv, Ukraine, Naukova Dumka Press, 1990.
- [20] Stukach OV, Iluschenko VN. "The design of transient functions based on differential conversion of time characteristics for linear systems". *Electronical Modelling*, 12(6), 97-98, 1990.
- [21] Chen CK, Ho SH. "Application of Differential Transformation to eigenvalue problems". *Applied Mathematics and Computation*, 79, 173-188, 1996.
- [22] Yu LT, Chen CK. "The solution of the Blasius equation by the Differential Transformation method". *Mathematical and Computer Modelling*, 28(1), 101-111, 1998.
- [23] Chen CK, Ho SH. "Solving partial differential equations by two dimensional Differential Transform". *Applied Mathematics and Computation*, 106, 171-179, 1999.
- [24] Abbasov T, Herdem S, Köksal M. "Modelling of distributed parameter nonlinear systems by differential Taylor method". *Control and Cybernetics*, 28(2), 259-267, 1999.
- [25] Herdem S, Mamiş MS, Abbasov T, Köksal M. "Numerical solutions of partial differential equations for electrical machines by differential Taylor transform". *Seventh International Colloquium on Numerical Analysis and Computer Science with Applications*, Plovdiv, Bulgaria, 13-17 August 1998.
- [26] Mamiş MS, Abbasov T, Herdem S, Köksal M. "Transient analysis of electrical machines by differential Taylor transform". *Proceedings of the International Conference on Power System Transients*, Budapest, Hungary, 20-24 June 1999.
- [27] Jang MJ, Chen CL, Liy YC. "On solving the initial-value problems using the differential transformation method". *Applied Mathematics and Computation*, 115, 145-160, 2000.
- [28] Jang MJ, Chen CL, Liu YC. "Two-dimensional differential transform for partial differential equations". *Applied Mathematics and Computation*, 121, 261-270, 2001.
- [29] Bert CW. "Application of differential transform method to heat conduction in tapered Fins". *Journal of Heat Transfer*. 124(1), 208-209, 2002.
- [30] Chen CK, Ju SP. "Application of differential transformation to transient advective-dispersive transport equation". *Applied Mathematics and Computation*, 155, 25-38, 2004.
- [31] Abdel-Halim Hassan IH. "Differential transformation technique for solving higher-order initial value problems". *Applied Mathematics and Computation*, 154, 299-311, 2004.
- [32] Abbasov T, Bahadır AR. "The investigation of the transient regimes in the nonlinear systems by the generalized classical method". *Mathematical Problems in Engineering*, 5, 503-519, 2005.
- [33] Hassan AH. "Comparison differential transformation technique with Adomian decomposition method for linear and nonlinear initial value problems". *Chaos, Solitons Fractals*, 36(1), 53-65, 2008.
- [34] Chang SH, Chang IL. "A new algorithm for calculating one-dimensional differential transform of nonlinear functions". *Applied Mathematics and Computation*, 195, 799-808, 2008.
- [35] Zou L, Wang Z, Zong Z. "Generalized differential transform method to differential-difference equation". *Physics Letters A*, 373, 4142-4151, 2009.
- [36] Rashidi MM. "The modified differential transform method for solving MHD boundary-layer equations". *Computer Physics Communications*, 180, 2210-2217, 2009.
- [37] Ravi Kanth ASV, Aruna, K. "Two-dimensional differential transform method for solving linear and non-linear Schrödinger equations". *Chaos, Solitons Fractals*, 41, 2277-2281, 2009.
- [38] Odiabat ZM, Bertelle R, Aziz-Alaoui R, Duchamp RHE. "A multi-step differential transform method and application to non-chaotic or chaotic systems". *Computers and Mathematics with Applications*, 59, 1462-1472, 2010.
- [39] Peker HA, Karaoğlu O, Oturaç G. "The differential transformation method and pade approximant for a form of Blasius equation". *Mathematical and Computational Applications*, 16(2), 507-513, 2011.
- [40] Peng HS, Chen CL. "Hybrid differential transformation and finite difference method to annular fin with temperature-dependent thermal conductivity". *International Journal of Heat and Mass Transfer*, 54(11-12), 2427-2433, 2011.
- [41] Fatoorehchi H, Abolghasemi H. "Computation of analytical Laplace transforms by the differential transform method". *Mathematical and Computer Modelling*, 56, 145-151, 2012.

- [42] Fatoorehchi H, Abolghasemi H. "Improving the differential transform method: a novel technique to obtain the differential transforms of nonlinearities by the Adomian polynomials". *Applied Mathematical Modelling*, 37, 6008–6017, 2013.
- [43] Salahshour S, Allahviranloo T. "Application of fuzzy Differential Transform method for solving fuzzy volterra integral equations". *Applied Mathematical Modelling*, 37, 1016–1027, 2013.
- [44] Suddoung K, Charoensuk J, Wattanasakulpong N. "Vibration response of stepped FGM beams with elastically end constraints using differential transformation method". *Applied Acoustics*, 77, 20–28, 2014.
- [45] Hatami M, Sheikholeslami M, Domairry G. "High accuracy analysis for motion of a spherical particle in plane Couette fluid flow by multi-step differential transformation method". *Powder Technology*, 260, 59–67, 2014.
- [46] Mosayebidorcheh S, Sheikholeslami M, Hatami M, Ganji DD. "Analysis of turbulent MHD Couette nanofluid flow and heat transfer using hybrid DTM–FDM". *Particuology*, 26, 95–101, 2016.
- [47] Sheikholeslami M, Ganji, Domiri D. "Nanofluid flow and heat transfer between parallel plates considering Brownian motion using DTM". *Computer Methods in Applied Mechanics and Engineering*, 283, 651–663, 2015.
- [48] Henson T, Arunagiri G. "Fundamental operation of differential transformation method". *International Journal of Mathematics and Its Applications*, 4(4), 75–81, 2016.
- [49] Rebenda J, Šmarda Z. "A differential transformation approach for solving functional differential equations with multiple delays". *Communications in Nonlinear Science and Numerical Simulation*, 48(2017), 246–257, 2017.
- [50] Odibat ZM, Kumar S, Shawagfeh N, Alsaedi A, Hayat T. "A study on the convergence conditions of generalized differential transform method". *Mathematical Methods in the Applied Sciences*, 40, 40–48, 2017.
- [51] Lin SY, MH Shao, Shih SP, Lu HY. "Application of differential transformation method to the human eye heat transfer problems". *Proceedings of IEEE International Conference on Applied System Innovation*, Taiwan, China, 13-17 April 2018.
- [52] Mohanty M, Jena SR. "Differential transformation method (DTM) for approximate solution of ordinary differential equation (ODE)". *Advances in Modelling and Analysis*, 61(3), 135–138, 2018.
- [53] Rashidi MM, Rabieli F, Naseri Nia S, Abbasbandy S. "A review: differential transformation method for semianalytical solution of differential equations". *International Journal of Applied Mechanics and Engineering*, 25(2), 122–129, 2020.
- [54] Huang C, Li J, Lin F. "A new algorithm based on differential transform method for solving partial differential equation system with initial and boundary conditions". *Advances in Pure Mathematics*, 10(5), 337–349, 2020.
- [55] Bunga EY, Ndi MZ. "Application of differential transformation method for solving HIV model with anti-viral treatment". *Jurnal Ilmu Matematika dan Terapan*, 14(3), 377–386, 2020.
- [56] Noori SRM, Taghizadeh N. "Modified differential transform method for solving linear and nonlinear pantograph type of differential and Volterra integro-differential equations with proportional delays". *Advances in Difference Equations*, 649(2020), 1-25, 2020.
- [57] Tamboli VK, Tandel PV. "Solution of time –fractional generalized Burger-Fisher equation using the fractional reduced differential transform method". *Journal of Ocean Engineering and Science*, 7(4), 399–407, 2021.
- [58] Bervillier C. "Status of the differential transformation method". *Applied Mathematics and Computation*, 218(20), 10158–10170, 2012.
- [59] Yavuz MM, Kanber B. "Effect of Higher Order Taylor Series Expansion Terms of the NI-RPIM on the Solution Accuracy of 2D Elastic Problems". *Pamukkale Üniversitesi Mühendislik Bilimleri Dergisi*, 21(1), 1-10, 2015.
- [60] Poularikas AD. *Signals and Systems Primer with MATLAB*. 1st ed. Boca Raton, Florida, USA, CRC Press, 2006.
- [61] Elliott EB. "Notes on dualistic differential transformations". *Proceedings of the London Mathematical Society*, 23(1), 188–202, 1891.
- [62] Hatami M, Ganji DD, Sheikholeslami M. *Differential Transformation Method for Mechanical Engineering Problems*. 1st ed. Cambridge, Massachusetts, USA, Academic Press, 2017.
- [63] Sheikholeslami M, Ganji DD. *External Magnetic Field Effect on Hydrothermal Treatment of Nanofluid: Numerical and Analytical Studies*. 1st ed. Amsterdam, Holland, William Andrew Press, 2016.
- [64] Shekar M. *The Application of Differential Transform Method to Nonlinear Equations Arising in Heat and Mass Transfer*. PhD Thesis, Gulbarga University, Kalaburagi, India, 2014.
- [65] Patel YF, Dhodiya JM. *Applications of Differential Transform to Real World Problems*. 1st ed. Boca Raton, Florida, USA, Chapman and Hall/CRC Press, 2022.
- [66] Saravanan A. *A Study on The Differential Transform Method for Certain Classes of Differential and Integral Equations*. PhD Thesis, Periyar University, Salem, India, 2017.
- [67] Zhou JK. *Differential Transformation and its Applications for Electrical Circuits*. PhD Thesis, Huazhong University, Wuhan, China, 1986.
- [68] Baligin VS. "Transient discharge current of a capacitor connected to a resistor with resistance linearly depending on the temperature". *Elektrichestvo*, 7, 68–71, 2002.