

Distraction and Focusing on the Management of Labour Pain: Stereograms

Abstract

Pharmacologic and non-pharmacologic methods are used in management of labour pain. In use of pharmacologic methods, the only role of woman in pain management role and control is to adapt passively. At the same time, pharmacologic methods and interventions require complex technologies and experienced personnel. In the event that pain control is enough, non-pharmacologic methods have many advantages compared to pharmacologic methods. They do not slow down the labour and do not have side effects or allergy risks. Distraction and focusing, which means drawing attention from pain to another direction, is one of the methods for coping with labour pain. Distraction and focusing are used to prevent transmission of painful stimulants to central neural system. It enables the pregnant woman to draw her attention from the pain and focus on other stimulants during contractions. Some object/ instrument/ implementation can be used for distraction and focusing. The aim of this paper is to explain the place of stereogram cards prepared specifically for labour in enabling the pregnant woman to cope with pain during her contractions. Stereogram focusing cards during labour (DSO-K) are designed specifically with oxytocic images. Consisting of 10 different cards, DSO-K enables women to draw their attention from pain during labour. As one of the non-pharmacologic methods implemented in labour, the method of focusing with DSO-K might be included among effective methods of relieving labour pain. The method of focusing with DSO-K is a safe, non-invasive independent method which does not require doctor's solicitation for nurses and midwives during labour. It is one of the easy, accessible and cheap methods that woman can use on her own and each woman can benefit during labour.

Keywords: Birth, distraction, labour pain, focusing, stereogram

Esra Yurtsev¹ 
Nevin Şahin² 

¹ Sariyer Hamidiye Etfal Training and Research Hospital, Istanbul, Turkey

² Department of Women's Health and Disease Nursing, Istanbul University-Cerrahpaşa, Florence Nightingale School of Nursing, Istanbul, Turkey

Introduction

Together with tissue damage, pain is a stimulus that is unpleasant, causes behavioral reactions in the individual, leads to a need for seeking help, is subjective, hard to describe, and complex.¹⁻⁴ Pain perception is affected by various factors such as the individual's gender, education, previous pain experiences, emotional and cognitive status, and culture. The meaning of pain and reactions given to pain vary greatly from individual to individual.^{4,5}

Labor is one of the most special moments of a woman's life. Being part of a unique process, labor pain develops as a response to increasing contractions and cervical dilatation during the course of labor, not as a result of tissue trauma or damage.^{6,7} Labor pain is a multidimensional, subjective phenomenon with sensual, emotional, motivational, and cognitive aspects.⁸ Labor pain perception varies in relation to the mother's physical and emotional state, fear, anxiety, coping skills, self-sufficiency expectations, and existence of social support.⁹ Furthermore, interventions during labor, such as use of oxytocin or misoprostol, administering epidural analgesia or anesthesia, and implementation of amniotomy, affect labor pain directly.¹⁰

Severe labor pain affects maternal and fetal health negatively by deteriorating the mother's emotional and mental health.⁶ It causes increased cardiac output and pulmonary ventilation, oxygen need, ineffective uterine contractions, prolonged labor, decreased uterine perfusion, metabolic acidosis, and increased obstetric interventions, hypoxia in the fetus, and decreased Apgar scores.^{6,10,11} Owing to the effects of severe labor pain on the mother and fetus, the American College of Obstetricians and Gynecologists (ACOG) and the American Society of Anesthesiologists (ASA) have reported that labor pain should be relieved and that they considered labor pain as a treatment indication.^{12,13} Pharmacologic and nonpharmacologic methods are used for relieving labor pain. In this article, we will discuss approaches used for labor pain management and stereograms as a distraction and focusing method.

Yurtsev E, Şahin N. Distraction and Focusing on the Management of Labour Pain: Stereograms. *J Educ Res Nurs*. 2021;18(2):196-201.

Corresponding Author: Esra Yurtsev
E-mail: e.yurtsev@hotmail.com

Received: May 11, 2019
Accepted: August 9, 2019



Copyright@Author(s) - Available online at www.jer-nursing.org
Content of this journal is licensed under a Creative Commons Attribution-NonCommercial 4.0 International License.

Approaches Used in Labor Pain Management

There are 2 different views on labor pain management. In the first view, a positive approach is exhibited, thinking that controlling pain with pharmacologic methods will increase a woman's comfort. In the second view, it is believed that a woman's successful adaptation to normal labor pain will yield positive results for both the mother and the infant in the long term.⁹ In practice, labor pain is brought under control by using pharmacologic and nonpharmacologic methods.^{2,5,14,15}

Pharmacologic pain control methods used during labor are systemic analgesics (tranquilisers, sedatives), inhalation analgesia, regional analgesia (paracervical block, pudendal block, lumbar-caudal epidural block, spinal block, combined spinal-epidural block, lumbar sympathetic block), local analgesia, and general anesthesia.^{16,17,18} Nonpharmacologic methods used for labor pain can be listed as breathing techniques, massage, touching, effleurage, hot or cold application, hydrotherapy, movement and positioning, focusing and distracting, hypnosis, labor preparation methods, labor support, imagining, music, aromatherapy, acupuncture, acupressure (Shiatsu), reflexology, homeopathy, subcutaneous electrical nerve stimulation (TENS) application, and percutaneous or subcutaneous sterile water injection.^{10,16,17,19-22}

There is evidence indicating that use of pharmacologic methods to relieve labor pain may lead to undesired side effects caused by prolonged stationary time associated with pharmacologic pain management. However, nonpharmacologic methods that are noninvasive are safe for both the mother's and infant's health and reduces possible obstetrical interventions.^{21,23} In addition, uninterrupted support given to a woman during labor reduces clinical complications before and during labor and in the postpartum period and increases satisfaction with labor experience.²⁴ According to the results of studies conducted, it was reported that women who use nonpharmacologic methods during the first phase of labor have lower pain scores, they are able to cope with labor pain more easily, and they have a more positive labor experience.²⁵⁻³³ However, labor services are influenced by a more risk oriented and technology-dominant approach in many environments.³⁴ Nurses and midwives working in the delivery room should know the pharmacologic and non-pharmacologic methods for coping with labor pain and the effects and limitations thereof, and they should offer support to the pregnant woman by effective implementation of those methods.¹⁶ All women should be able to access nonpharmacologic methods for controlling pain during labor.^{19,21,22} Health care service providers should accompany women during the labor process and ensure that the labor is carried out safely by supporting the woman without interruption.³⁴

Distraction and Focusing in Pain Control

Distraction and focusing means diverting the attention away from pain and directing it to another stimulus.^{15,35,36} In painful situations, strategies for taking attention away from pain and focusing on stimulants other than pain can be used alone or together with medication or before implementing pharmacologic methods. Although these cognitive strategies are effective for mild pain over a long time period in general, they may prove to be an effective way to relieve even severe pain.³⁵⁻³⁷

Distraction and focusing reduces pain perception by blocking the transmission of pain signals perceived during contraction to the pain center.³⁸ Gate control theory was suggested in 1965 by Melzack and Wall. The dorsal horn of the spinal cord functions as a gate and plays a dynamic role in the process of transmitting pain to the brain.^{39,40} Transmission of painful stimuli is carried out by the substantia gelatinosa (SG) cells, dorsal horn, and T cells in the spinal cord. The SG cells in the dorsal horn transmit stimuli to the T cells, and painful stimuli are transmitted to the brain. According to the gate control theory, thin my-

elinated A-delta fibers and unmyelinated C fibers are responsible for pain transmission. Thin myelinated A-delta fibers facilitate pain transmission by inhibiting the SG cells; in other words, they open the gate and allow painful stimuli to reach the cognitive level. Thick, unmyelinated C fibers inhibit pain transmission by stimulating SG cells; they prevent painful stimuli from reaching cognitive level by closing the gate.⁴¹⁻⁴⁴ This gate in the dorsal horn is closed and prevents transmission of pain by focusing the cerebral cortex on those stimuli by using visual and auditory stimulative techniques, focal points, or breathing techniques.^{42,45}

Research on pain management with gate control theory is based on cognitive behavioral approaches. This theory explains how the interventions based on somatosensorial stimuli do not transmit painful stimuli to the superconscious and how it reduces pain perception.⁴⁶ The individual's pain is not completely eliminated in this way, but their tolerance and sense of control over the pain is increased.⁴⁷

Various objects, practices, and tools can be used for diverting attention away from pain. Distraction can be achieved by means of counting, singing, listening to music, praying, or inner affirmation such as repeating expressions like "I can cope." Watching a movie or television or listening to music are also distraction methods.^{15,35} Paying attention to respiration by inhaling and exhaling slowly and in a rhythmic manner can help relaxation. Focusing on a nearby object and trying to describe something in detail (where, how big, what, etc.) might be an alternative as well.^{36, 37}

Areas in which Distraction and Focusing for Pain Control is Used

Among nonpharmacologic methods used for reducing pain levels, it is seen that visual auditory distraction and focusing methods are used in various fields.^{48,49} In literature, it is reported that "Plippets" cards are used to draw attention to another stimulus, thereby reducing pain perception during bloodletting in 6- to 12-year-old children.⁵⁰⁻⁵² Another method used for reducing pain perception in previous studies is a virtual reality method, which is based on focusing a patient's attention to another stimulus.⁵³⁻⁵⁸ In their study on the impact of virtual reality on pain perception during episiotomy repair, Shourab et al⁵⁹ reported that using a virtual reality method is effective in reducing pain perception by drawing attention away from the pain.

Distraction and Focusing in Labor

Distraction during labor is a process in which a woman draws her attention away from labor pain with stimulants from her surroundings.^{45,60,61} It is known that women walk around, sit in a chair, talk to visitors, watch television, play cards, and use their phone involuntarily during labor to get away from pain. Most women come to a point during labor in which they cannot speak easily because of the contractions. During labor, preserving the sense of control is a difficult situation that requires intense concentration.^{45,61} Most of the coping methods for pain require focusing the attention or individual's conscious participation on mind guidance activities.^{15,36,61} It is important to guide attention toward a stimulus other than pain during contractions.^{15,16} The woman can take her mind away from pain by focusing on visual, auditory, and tactile stimulants (touching and massage). Focusing on an object in the room or the eyes of the partner may help a women to focus.⁶⁰ Self-hypnosis, guiding attention to self, or focusing on visual stimulants can be used.^{36,38} Some women may prefer closing their eyes, whereas others want to focus on an external object. Keeping their eyes open and focusing on an area outside the body helps a woman to drift away from her pain.⁴² By specifically establishing a focal point allows maintenance of concentration. Pictures and small in-

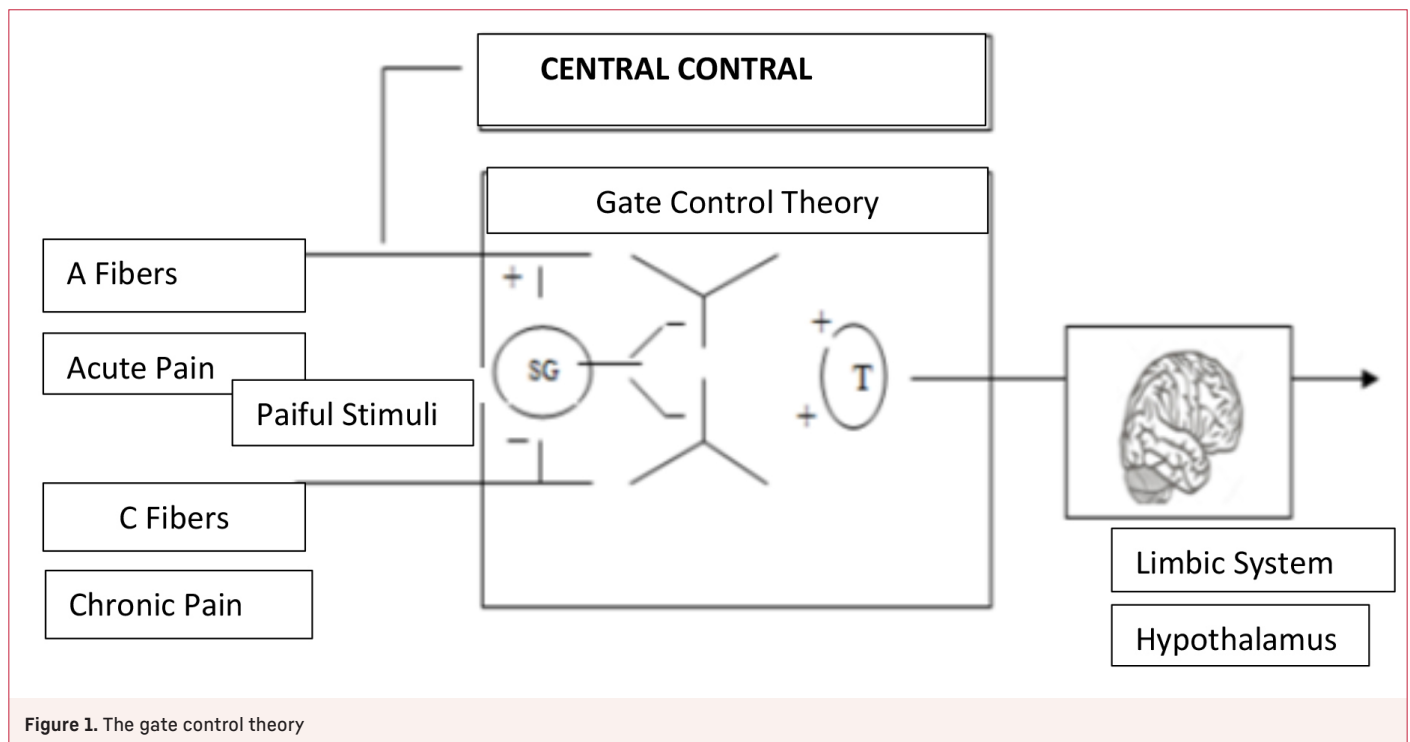

Figure 1. The gate control theory

animate objects can be used as focal points during labor. Focal points help maintain concentration on an area.^{16,42} If no focal point is determined beforehand, they can focus on any object in the room during labor.^{16,42,61,62} Pregnant women may also use their personal belongings that they have brought from home as focal points. They may also draw their attention away from pain by maintaining eye contact with the person who is with them or health care professionals who help them during labor.¹⁶ As another option, they may focus on an image in their mind.^{36,38,62} They may focus on a moment, place, or event in which they felt relaxed and happy. They could imagine being on a beach or on top of the mountains^{36,38}; walking in the garden; positive visualization such as envisioning colors that give light, energy, and healing⁶²; by imagining that breath takes away all concerns and tension⁶²; or that the contractions of the uterus muscle causes opening of the cervix and the infant's progress in the birth canal might help to keep the mind away from pain.^{36,38,42,61} In the focusing technique with envisioning in mind, choosing the topic beforehand for the image to be envisioned and implementing the technique and practicing during pregnancy increase the efficiency of this practice during labor.⁶²

Stereograms as Distraction and Focusing Tools in Management of Labor Pain

The viewing technique of stereograms discovered by Charles Wheatstone in 1838 is also based on focusing. Stereogram is the general name for 2-dimensional (2D) images that create 3-dimensional (3D) perceptions in the mind.⁶³ A person is able to trick their mind to see the 3D images by focusing their lenses on the stereogram and converging their eyes on a distant point behind the stereogram image.⁶⁴⁻⁶⁸ Known as "şaşı bak şaşır" in Turkey in the 1990s, stereograms became popular especially in the United States of America in the "Magic Eye" book series.⁶³

There are different methods used to see the intended 3D image in the stereogram. Although some people are able to see the 3D images in a stereogram easily, others have to train their eyes to distinguish the

eye convergence caused by lens focusing.^{64,69} One of the methods that can be used to see the image in the stereograms is to keep the image right in front of the face and with the nose touch the image. Most people cannot focus on the image when it is too close to their eyes. If the person slowly takes the image away from their face, the brain focuses on pattern pairs corresponding to the current convergence degree of the 2 eyes at 1 point.⁷⁰ Another method is to look at an object behind the image as fixed while keeping the visual field fixed on the image to obtain the suitable convergence degree with the purpose of persuading the brain to focus on the image. In an altered method, a person looks at his reflection on the bright surface of the image as fixed; thus, while the brain focuses on the nearby image, it will achieve the required convergence degree and enable the viewer to see the 3D image behind the pattern.⁷⁰

The structure of Stereogram Focusing Cards in Labor (DSO-K) consists of 2 images. One of them is a depth map and the other is a texture map. These 2 visual elements are combined with specially designed computer software.⁶³ DSO-K are original works designed specifically for labor and created using stereogram creator software. When designing DSO-K, the silhouettes of pregnant women, fathers, and infants that will draw the attention of the mothers are used as oxytocic images in the texture maps. Oxytocin is known as the love hormone and feelings of love increase the secretion of oxytocin.⁷¹ Images and patterns used in DSO-K decks are selected in compliance with this feature of the oxytocin hormone. A DSO-K deck consisting of 10 different cards designed specifically with oxytocic images draws the women's attention from pain during labor. In an experimental study, it was seen that focusing on stereogram cards that were designed specifically for labor during contractions reduced the perception of labor pain among pregnant women and affected the labor process positively.⁷² It was shown in that experimental study that women whose labor pain was reduced experienced less anxiety and less fatigue after labor.⁷² In the same study, it was reported that the duration of the active phase of labor among women who focused on DSO-K was shorter.⁷² All these

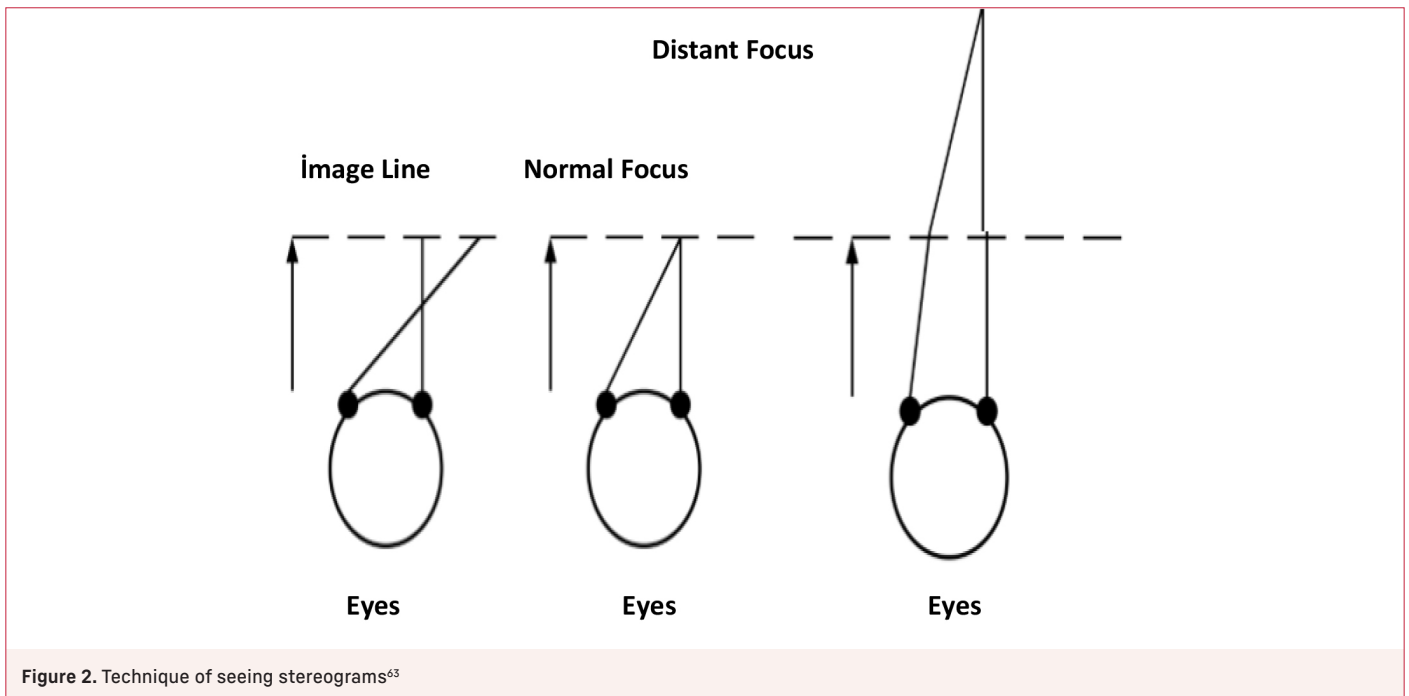

Figure 2. Technique of seeing stereograms⁶⁵

data indicate that pain is a determinant of the labor experience and that positive antenatal and postnatal results can be achieved when pain perception is changed using the method of focusing with DSO-K.

Training for Focusing on DSO-K Method

With the purpose of facilitating the use of DSO-K during labor, it is recommended that applied training on the techniques of focusing on stereogram cards is provided to pregnant women in the last trimester. The content of the training to be given to pregnant women should include information about the impact of focusing on labor pain perception, aim of DSO-K, a demonstration of viewing techniques for DSO-K, and the antenatal training should be completed by providing pregnant women with sample cards to practice. Training in the method of focusing on antenatal DSO-K enables pregnant women to apply the method successfully during labor. However, training in the method of focusing on DSO-K can be provided to the pregnant women when they are admitted to the delivery room with low contraction severity and a cervical gap of less than 3 to 4 cm.

Advantages and Limitations of the Method

Designed specifically for labor, DSO-K is a good tool that can be used to provide a focal point for women during labor. Focusing attention on another stimulus separate from the pain during contractions lowers a woman's pain perception. Being low cost and easy to implement, noninvasive, and not requiring a doctor's permission are important advantages. Viewing techniques for DSO-K can be taught to all pregnant women admitted to the delivery room using a short demonstration, and pregnant women can easily implement the method on their own after the training. It is a tool that can be used to distract pregnant women during prolonged labors. DSO-K needs promotion to become generalized and available for use in every delivery room and antenatal training classes.

Although it might seem like a disadvantage that the method requires active participation from pregnant women and that pregnant women require training on viewing techniques, cooperation with the pregnant women can be ensured quite easily. The fact that DSO-K is a new

method, the cards are in the process of patenting, and there is only one experimental study of the impact of DSO-K on labor pain perception can be listed as limitations of this method.

Conclusion

When the criteria for a mother- and infant-friendly hospital are examined, the independent roles and functions of nurses and midwives such as training, consultancy, and supporting mothers are important for achieving the desired standards and executing safe motherhood services. Using DSO-K as a method of focus during labor can be included among the nonpharmacologic effective methods that can be applied to relieve labor pain. Focusing using the DSO-K method is a safe, noninvasive, independent intervention that can be applied by nurses and midwives during labor without a doctor's consent. It is one of the easy, accessible, and affordable methods that can be implemented independently by pregnant women and every woman can benefit from it during labor. Nurses and midwives can request more information about the method from the authors.

Peer-review: Externally peer-reviewed.

Author Contributions: Concept – N.H.Ş., E.Y.; Design – E.Y.; Supervision – N.H.Ş., E.Y.; Literature Search – E.Y.; Writing – E.Y.; Critical Reviews – N.H.Ş.

Conflict of Interest: The authors have no conflict of interest to declare.

Financial Disclosure: The authors declared that this study has received no financial support.

References

1. Eti Aslan F. Ağrı değerlendirme yöntemleri. *C.Ü. Hemşirelik Yüksekokulu Dergisi*. 2020;6(1):9-16.
2. Hamidzadeh A, Shahpourian F, Orak RJ, Montazeri AS, Khosravi A. Effects of LI4 acupressure on labor pain in the first stage of labor. *J Midwifery Womens Health*. 2021;57(2):133-138. [\[Crossref\]](#)
3. Korkan EA, Uyar M. Ağrı kontrolünde kanıt temelli yaklaşım: refleksoloji. *ACU Sağlık Bil Derg*. 2014;5(1):9-14.
4. Köksal Ö, Duran ET. Doğum ağrısına kültürel yaklaşım. *DEUHYO ED*. 2013;6(3):144-148.

5. Simkin P, Bolding A. 2004. Update on nonpharmacologic approaches to relieve labor pain and prevent suffering. *J Midwifery Womens Health*. 2004;49(6):489-504. [\[Crossref\]](#)
6. Akbarzadeh M, Masoudi Z, Zare N, Vaziri F. Comparison of the effects of doula supportive care and acupressure at the BL32 point on the mother's anxiety level and delivery outcome. *J Nurs Midwifery Res*. 2015;20(2):239-246.
7. Woo JH, Kim JH, Lee GY, et al. The degree of labor pain at time of epidural analgesia in nulliparous women influences the obstetric outcome. *Korean J Anesthesiol*. 2015;68(3):249-253. [\[Crossref\]](#)
8. Klomp T, Mannien J, Jonge A, Hutton EK, Lagro-Janssen A. What do midwives need to know about approaches of women towards labour pain management? A qualitative interview study into expectations of management of labour pain for pregnant women receiving midwife-led care in the Netherlands. *Midwifery* 2014;30(4):432-438. [\[Crossref\]](#)
9. Madden KL, Turnbull D, Cyna AM., Adelson P, Wilkinson C. Pain relief for childbirth: the preferences of pregnant women, midwives and obstetricians. *Women Birth*. 2013;26(1):33-40. [\[Crossref\]](#)
10. Ergin AB, Kömürçü N. Doğum ağrısında farmakolojik olmayan yöntemlerin kullanımı. *Hemşirelikte Eğitim ve Araştırma Dergisi*. 2009;6(2):29-35.
11. Dabiri F, Shah A. The Effect of L4 acupressure on labor pain intensity and duration of labor: a randomized controlled trial. *Oman Med J*. 2014;29(6):425-429. [\[Crossref\]](#)
12. American Collage of Obstetricians and Gynecologists Committee on Obstetric Practice: ACOG committee opinion. No.339: Analgesia and cesarean delivery rates. *Obstet Gynecol*. 2006;107(6):1487-1488. [\[Crossref\]](#)
13. ASA. 2010. Committee of Origin: Obstetrical Anesthesia (Approved by the ASA House of Delegates on October 13, 1999 and last amended on October 20).
14. Howard DE. An innovation in the assessment of labor pain. *J Perinat Neonatal Nurs*. 2017;31(2):96-98. [\[Crossref\]](#)
15. Avcıbay B, Alan S. Doğum ağrısı kontrolünde non-farmakolojik yöntemler. *Mersin Üniversitesi Sağlık Bilimleri Dergisi*. 2011;4(3):18-24.
16. Yıldırım G, Şahin, NH. Doğum ağrısının kontrolünde hemşirelik yaklaşımı. *Cumhuriyet Üniversitesi Hemşirelik Yüksek okulu Dergisi*. 2003;7(1):14-19.
17. Dağlar G, Aydemir N. Vajinal Doğum Ağrısının Azaltılmasına Yönelik Non-farmakolojik Ebelik Bakım Uygulamaları. *STED*. 2011;20(1):1-6.
18. Özdamar D. 2013. Doğum ağrısının kontrolünde farmakolojik Yöntemler Bölüm 5. Syf 48-58. Editör: Kömürçü N. doğum ve ağrısı yönetimi kitabı. 2. Baskı. Nobel Matbaacılık. İstanbul
19. Robertson E, Johansson SE. Use of complementary, non-pharmacological pain reduction methods during childbirth among foreign-born and Swedish-born women. *Midwifery*. 2010;26(4):442-449. [\[Crossref\]](#)
20. Gayeski ME, Brüggemann OM, Monticelli M, Atherino dos Santos KE. Methods to relieve pain during labor: the point of view of primiparous women. *Pain Manag Nurs*. 2015;16(3):273-84. [\[Crossref\]](#)
21. Jones L, Othman M, Dowswell T, et al. Pain Management for women in labour: an overview of systematic reviews (review). *Cochrane Database Syst Rev*. 2012;2012(3):CD009234. [\[Crossref\]](#)
22. Adams J, Frawley J, Steel A, Broom A, Sibbritt D. 2015. Use of pharmacological and non-pharmacological labour pain management techniques and their relationship to maternal and infant birth outcomes: Examination of a nationally representative sample of 1835 pregnant women. *Midwifery*. 2015;31(4):458-463. [\[Crossref\]](#)
23. Chaillet N, Belaid L, Crochetière C, et al. Nonpharmacologic approaches for pain management during labor compared with usual care: a meta-analysis. *Birth*. 2014;41(2):122-137. [\[Crossref\]](#)
24. Gruber KJ, Cupiton SH, Dobson CF. Impact of doulas on healthy birth outcomes. *Med J Perinat Educ*. 2013;22(1):49-58. [\[Crossref\]](#)
25. Dehcheshmeh FS, Rafiei H. 2015. Complementary and alternative therapies to relieve labor pain: A comparative study between music therapy and Hoku point icemassage. *Complement Ther Clin Pract*. 2015;21(4):229-232. [\[Crossref\]](#)
26. Downe S, Finlayson K, Melvin C, et al. 2015. Self-hypnosis for intrapartum pain management in pregnant nulliparous women: a randomised controlled trial of clinical effectiveness. *BJOG*. 2015;122(9):1226-34. [\[Crossref\]](#)
27. Finlayson K, Downe S., Hinder S, Carr H, Spiby, H., Whorwell, P. Unexpected consequences: women's experiences of a self-hypnosis intervention to help with pain relief during labour. *BMC Pregnancy Childbirth* 2015;15:229. [\[Crossref\]](#)
28. Hosseini SE, Bagheri M, Honarparvaran N. Investigating the effect of music on labor pain and progress in the active stage of first labor. *Eur Rev Med Pharmacol Sci*. 2013;17:1479-1487.
29. HanjaniSM, Tourzani ZM, Shoghi M. The effect of foot reflexology on anxiety, pain, and outcomes of the labor in primigravida women. *Acta Med Iran*. 2015;53(8):507-511.
30. Boaviagem A, Junior EM, LubamboL, et al. The effectiveness of breathing patterns to control maternal anxiety during the first period of labor: A randomized controlled clinical trial. *Complement Ther Clin Pract*. 2017;26:30-35. [\[Crossref\]](#)
31. Ünalmiş S, Yanikkerem E, Goker A. Effects of low back massage on perceived birth pain and satisfaction. *Complement Ther Clin Pract*. 2017;28:169-175. [\[Crossref\]](#)
32. Jahdi F, Sheikhan F, Haghani H, et al. Yoga during pregnancy: The effects on labor pain and delivery outcomes (A randomized controlled trial). *Complement Ther Clin Pract*. 2017;27:1-4. [\[Crossref\]](#)
33. Shahoei R, Shahghebi S, Rezaei M, Naqshbandi S. The effect of transcutaneous electrical nerve stimulation on the severity of labor pain among nulliparous women: A clinical trial. *Complement Ther Clin Pract*. 2017;28:176-180. [\[Crossref\]](#)
34. Hodnett ED, Gates S, Hofmeyr GJ, Sakala C, Weston J. Continuous support for women during childbirth. *Cochrane Database Syst Rev*. 2012;10:CD003766. [\[Crossref\]](#)
35. NIH. 2003. Pain kontrol: A guide for people with their families. National Institutes of Health and National Cancer Institute. 20.07.2017. <http://www.emory.edu/KomenEd/PDF/Treatment/Pain%20Control.pdf>. [\[Crossref\]](#)
36. Prasertcharoensuk W, Thinkhamrop J. Non-Pharmacologic Labour Pain Relief. *J Med Assoc Thai*. 2004;87(Suppl 3):203-206.
37. Lioffi C, Franck L: Psychological interventions for acute pediatric pain. In *Clinical Pain Management Acute Pain*. Edited by Macintyre P, Rowbotham D, Walker S. London: Hodder Arnold; 2008:308-323.
38. Simkin P, O'hara MA. Nonpharmacologic relief of pain during labor; systematic reviews of five methods. *Am J Obstet Gynecol*. 2002;186;131-159. [\[Crossref\]](#)
39. Melzac R. From the gate to the neuromatrix. *Pain*. 1999;Suppl 6:S121-S126. [\[Crossref\]](#)
40. Trout KK. The neuromatrix theory of pain: implications for selected nonpharmacologic methods of pain relief for labor. *J Midwifery Womens Health*. 2004;49(6):482-488. [\[Crossref\]](#)
41. Mccool WF, Smith T, Aberg C. Pain in women's health: a multi-faceted approach toward understanding. *J Midwifery Womens Health*. 2004;49(6):473-481. [\[Crossref\]](#)
42. Murray S, McKinney E. Pain relief and comfort measures in labor (4th ed) *Foundations of maternal -newborn nursing*; 2005;335-375.
43. Moayedı M, Davis, KD. Theories of pain: from specificity to gate control. *J Neurophysiol*. 2013;109:5-12. [\[Crossref\]](#)
44. Field T. Pregnancy and labor massage. *Expert Rev Obstet Gynecol*. 2010;5(2): 177-181. [\[Crossref\]](#)
45. Creehan PA. Pain Relief and Comfort Measure in Labor. İçinde Kathleen Rice Simpson, Patricia A. Creehan (3rd Ed). *Awhonn's Perinatal Nursing* 2007;333-460.
46. Currentnursing.com 2012. Gate Control Theory. http://currentnursing.com/nursing_theory/Gate_control_theory.html. Gate kontrol theory data of lasta revision: february. 05.07.2017.
47. Özveren H. Ağrı Kontrolünde Farmakolojik Olmayan Yöntemler. *Sağlık Bilimleri Fakültesi Hemşirelik Dergisi*. 2011;8(1):83-92.
48. Choudhury N, Amer I, Daniels M, Wareing MJ. Audiovisual distraction reduces pain perception during aural microsuction. *Ann R Coll Surg Engl*. 2013;95(1)34-36. [\[Crossref\]](#)
49. Oliveira NCAC, Santos JLF, Linhares MBM. Audiovisual distraction for pain relief in paediatric inpatients: A crossover study. *Eur J Pain*. 2016;21(1):178-187. [\[Crossref\]](#)
50. SahinerNC, Bal MD. 2015. The effects of three different distraction methods on pain and anxiety in children. *J Child Health Care*. 2016;20(3):277-285. [\[Crossref\]](#)
51. Canbulat N, İnal S, Sönmez H. Efficacy of distraction methods on procedural pain and anxiety by applying distraction cards and kaleidoscope in children. *Asian Nurs Res (Korean Soc Nurs Sci)*. 2014;8(1):23-28. [\[Crossref\]](#)

52. Aydın D, Şahiner NC, Çiftçi, EK. Comparison of the effectiveness of three different methods in decreasing pain during venipuncture in children: ball squeezing, balloon inflating and distraction cards. *J Clin Nurs*. 2016;25(15-16):2328-2335. [\[Crossref\]](#)
53. Chan EA, Chung JW, Wong TK, Lien AS, Yang JY. Application of a virtual reality prototype for pain relief of pediatric burn in Taiwan. *J Clin Nurs*. 2007;16:786-793. [\[Crossref\]](#)
54. Hoffman HG, Patterson DR, Seibel E, Soltani M, Jewett-Leahy L, Sharar SR. Virtual reality pain control during burn wound debridement in the hydro-tank. *Clin J Pain*. 2008;24:299-304. [\[Crossref\]](#)
55. Mott J, Bucolo S, Cuttle L, et al. The efficacy of an augmented virtual reality system to alleviate pain in children undergoing burns dressing changes: a randomised controlled trial. *Burns*. 2008;34:803-808. [\[Crossref\]](#)
56. Mahrer NE, Gold JI. The use of virtual reality for pain control: a review. *Curr Pain Headache Rep*. 2009;13(2):100-109. [\[Crossref\]](#)
57. Li A, Montañó Z, Chen VJ, Gold J. Virtual reality and pain management: current trends and future directions. *Pain Manag*. 2011;1(2):147-157. [\[Crossref\]](#)
58. Guo C, Deng H, Yang J. Effect of virtual reality distraction on pain among patients with hand injury undergoing dressing change. *J Clin Nurs*. 2015;24(1-2):115-120. [\[Crossref\]](#)
59. Shourab NJ, Zagami ES, Golmakhani N, et al. Virtual reality and anxiety in primiparous women during episiotomy repair. *Iran J Nurs Midwifery Res*. 2016;21(5):521-526. [\[Crossref\]](#)
60. Kömürçü N, Ergin A.B. 2013. Doğum Ağrısı ve Yönetimi, Kömürçü N. (Ed). 2. Baskı. İstanbul, Bedray Basın Yayıncılık, 40-45.
61. Simpson KR, O'brien-Abel N. 2014. Labor and Birth. Simpson KR, Creehan PA. (4th Ed.), *AWHONN Perinatal Nursing*. 344-510
62. Zauderer CR. Maximizing Comfort for the laboring woman. Lowdermilk LD, Perry ES, Cashion K, Alden KR. *Maternity women's health care*. 11. Edt. 2016; p.381-454.
63. Altunoglu ÖS. Stereogram types and structures. İnternet Erişim Adresi: 10.01.2017. [\[Crossref\]](#)
64. Pinker S. "The Mind's Eye", *How the Mind Works*; 1997;211-233.
65. Gantz L, Bedell HE. Transfer of perceptual learning of depth discrimination between local and global stereograms. *Vision Res*. 2010;50(18):1891-1899. [\[Crossref\]](#)
66. Gómez AT, Lupón N, Cardona G, Aznar-Casanova AJ. Visual mechanisms governing the perception of auto-stereograms. *Clin Exp Optom*. 2012;95:146-152. [\[Crossref\]](#)
67. Kimmel R. 3D shape reconstruction from autostereograms and stereo. *J Vis Commun Image Represent*. 2002;13(1-2):324-333. [\[Crossref\]](#)
68. Fang L, Grossberg S. From stereogram to surface: how the brain sees the world in depth. *Spat Vis*. 2009;22(1):45-82. [\[Crossref\]](#)
69. Webber AL, Wood J. "Amblyopia - prevalence, natural history, functional effects and treatment". *Clin Exp Optom*. 2005;88(6):365-375. [\[Crossref\]](#)
70. Grossman M, Smith C. 2004. *Magic Eye Beyond 3D: Improve Your Vision*. Kansas City: Andrews McMeel Publishing. ISBN 0-7407-4527-1.
71. Moberg KU. *The Oxytocin Factor: Tapping the Hormone of Calm, Love and Healing*; Edition, (A Merloyd Lawrence Book) Publisher: Da Capo Press Inc [Hardcover] Hardcover; 2003.
72. Yurtsev E. Doğuma Özel Stereogram Kartlarının Doğum Ağrısı Algısına Etkisi (Doktora Tezi). İstanbul: İstanbul Üniversitesi, Sağlık Bilimleri Enstitüsü; 2017.